

SECTION A-A

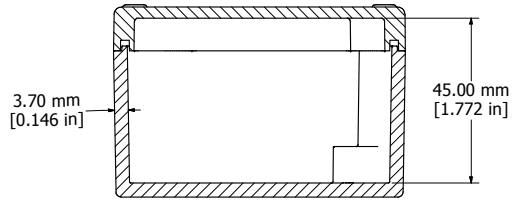

SECTION C-C



File #E65324

NEMA 4, 4X

Enclosures can be Factory Modified ( Milling, Drilling, Printing etc. )  
 Contact Factory [mjm@hammondmgf.com](mailto:mjm@hammondmgf.com) for quotes  
 Solid models of this enclosure available in STEP or IGES.

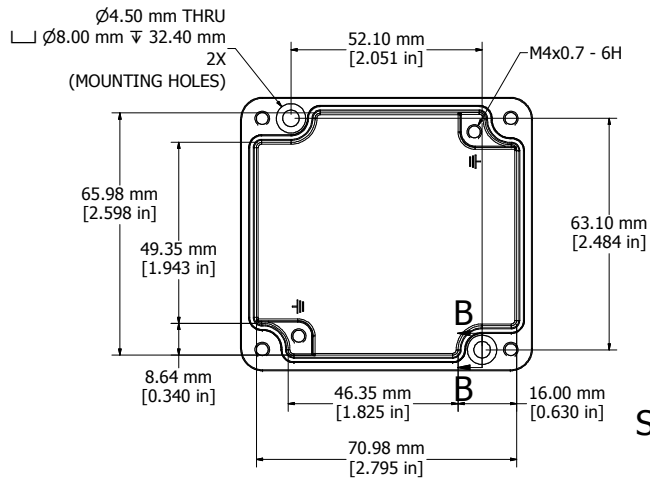

SECTION B-B

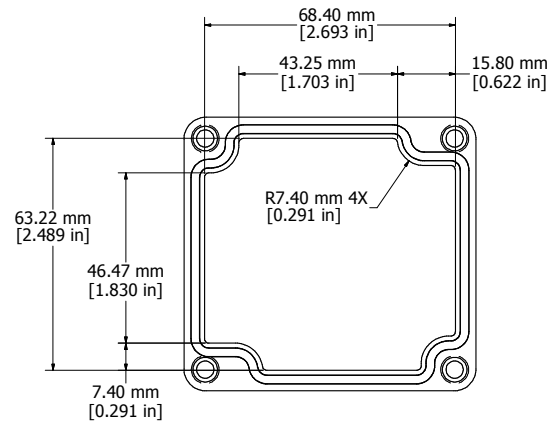
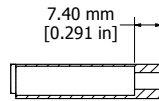

LID - INSIDE

**NOTES**

Purchased assembly includes enclosure, M4x25 lid screws and M4x6 ground screws.

Gasket - Preformed Silicone Rubber

Cover screws should be torqued to 5-7.5 lbf.in (50-75 cN.m)

**1590Z110**

**PART NUMBERS**

Basic Enclosure	1590Z110
Black Enclosure	1590Z110BK
Grey Enclosure - RAL7001 Gloss	1590Z110GY

