

ASSEMBLY

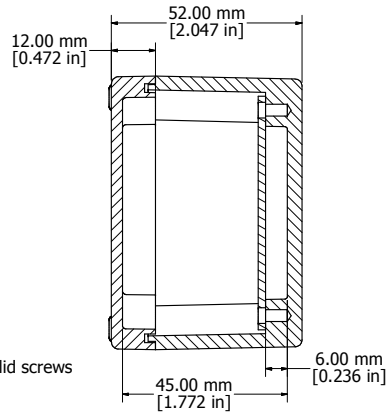

SECTION A-A

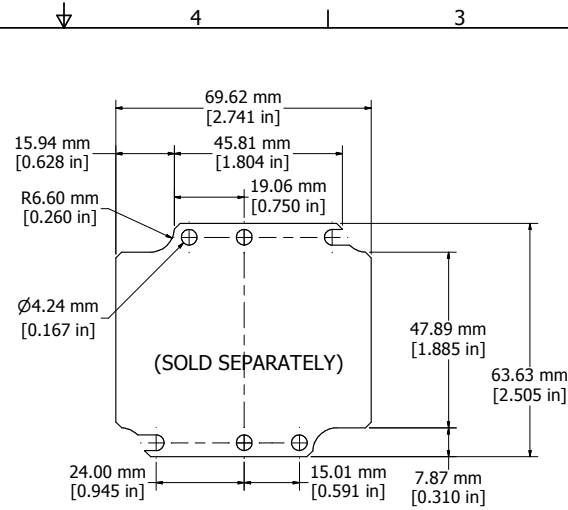

1590Z100PL

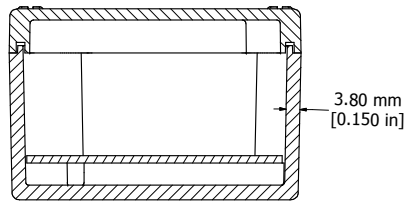

SECTION C-C

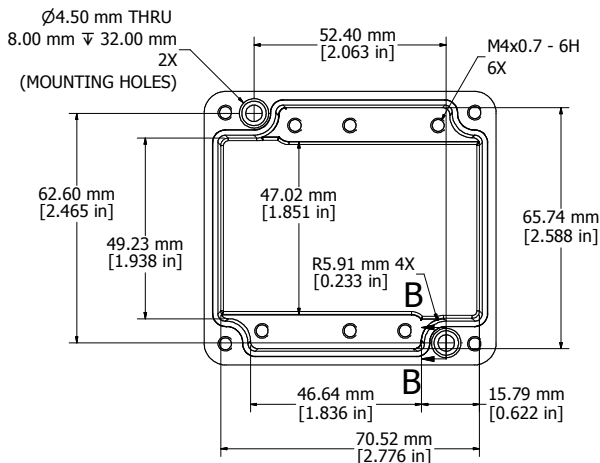

BOX - INSIDE

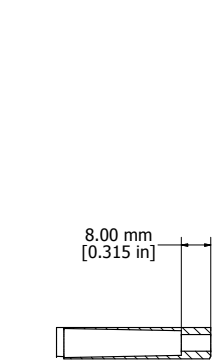

SECTION B-B

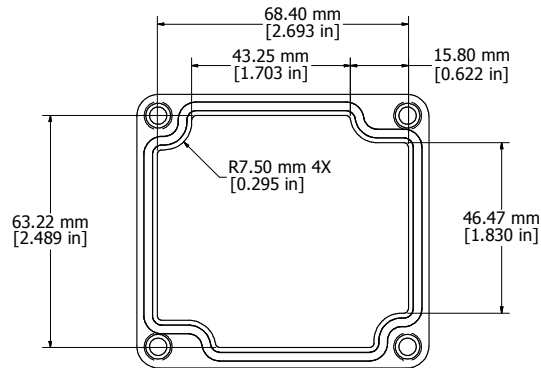

LID - INSIDE



File #E65324
NEMA 4, 4X

Enclosures can be Factory Modified (Milling, Drilling, Printing etc.)
Contact Factory mjm@hammondmfg.com for quotes
Solid models of this enclosure available in STEP or IGES.

NOTES	
Purchased assembly includes enclosure, M4x25 lid screws and M4x6 ground screws.	
Gasket - Preformed Silicone Rubber	
Cover screws should be torqued to 5-7.5 lbf.in (50-75 cN.m)	

1590Z100	
PART NUMBERS	
Basic Enclosure	1590Z100
Black Enclosure	1590Z100BK
Grey Enclosure - RAL7001 Gloss	1590Z100GY
ACCESSORIES	
Inner Panel	1590Z100PL

