

ASSEMBLY

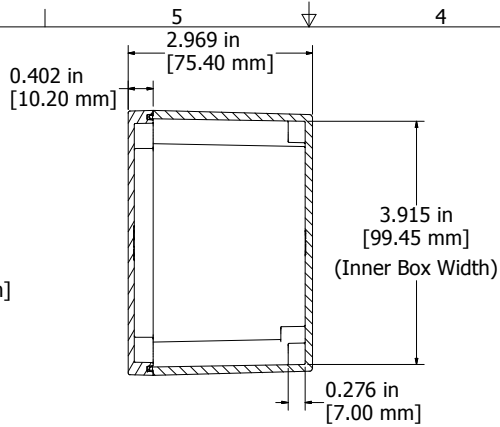

SECTION A-A  
End View of Assembly

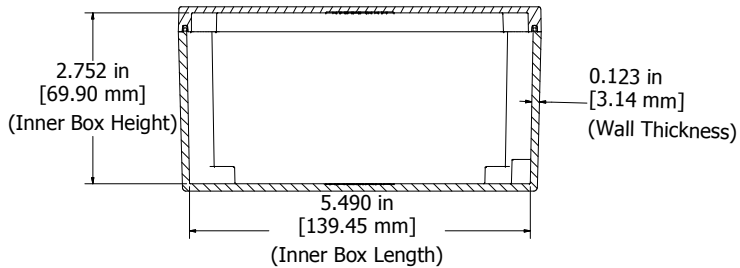
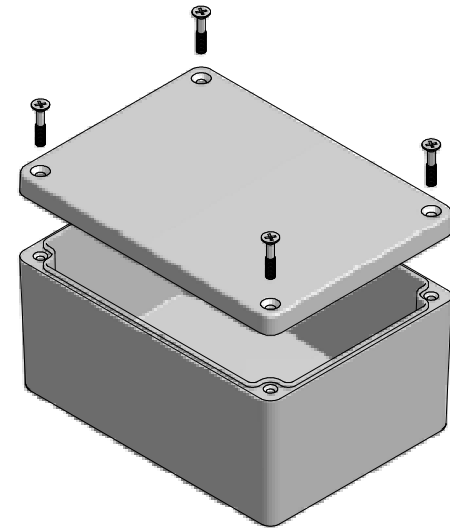

SECTION B-B  
Side View of Assembly

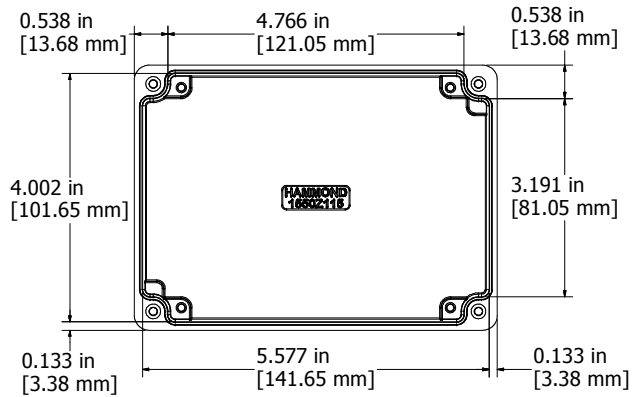

Top View Looking Inside Box

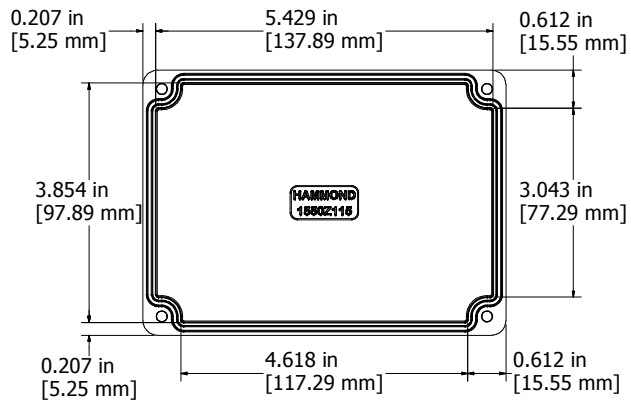

View Looking Inside Box

Enclosures can be Factory Modified ( Milling, Drilling, Printing etc. )  
 Contact Factory [mjm@hammondmfg.com](mailto:mjm@hammondmfg.com) for quotes  
 Solid models of this enclosure available in STEP or IGES.

NOTES	
Purchased assembly includes enclosure, M4x20 lid screws	
Gasket - Pre-formed Silicone Rubber	
Cover screws should be torqued to 5-7.5 lbf.in (50-75 cN.m)	

1550Z115	
PART NUMBERS	
Unfinished	1550Z115
Black Textured Powder Paint - RAL 9011	1550Z115BK

