

NOTES

MATERIAL - DIECAST ALUMINUM ALLOY
 - FOUR M12 CAPTIVE SCREWS

POWDER COATED - Col. RAL 7032
 GASKET - POLYURATHANE
 -40°C TO +80°C TEMP. RANGE

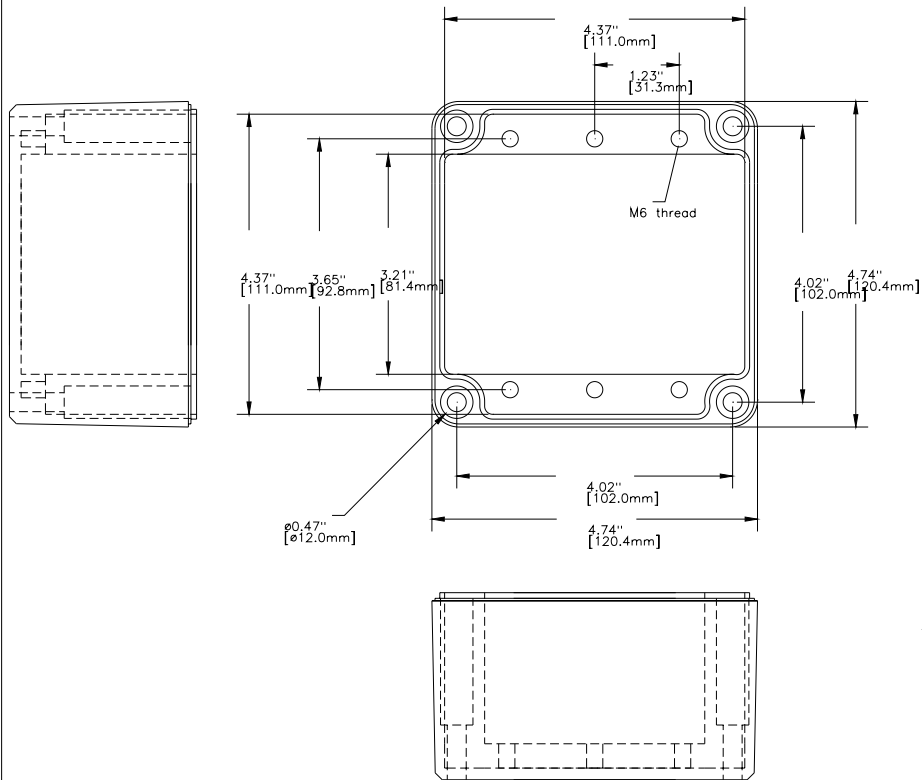
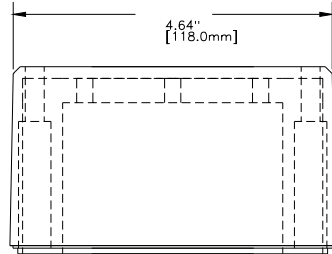

VIEW OF BOX (LID REMOVED)

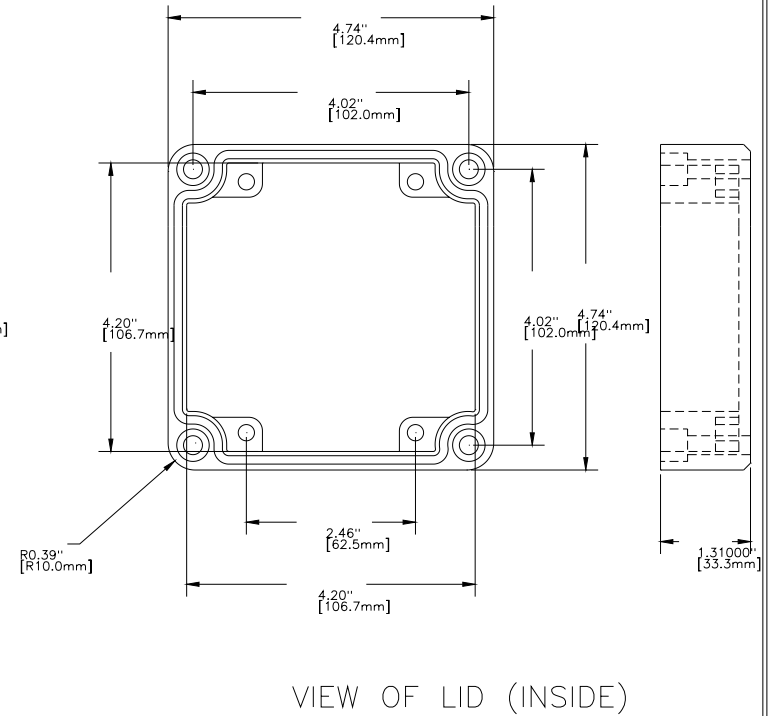
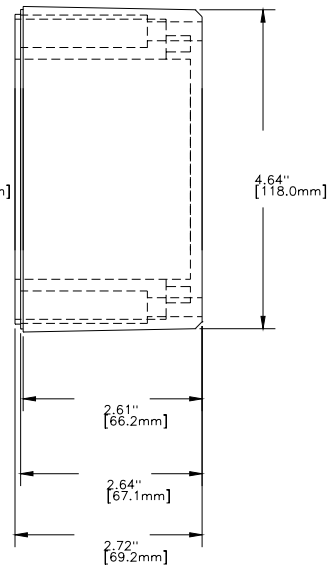

VIEW OF LID (INSIDE)

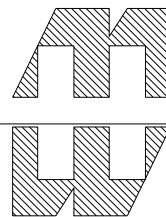

HAMMOND MANUFACTURING

R100-120-000