

Fan Tray

300, 600 and 900 CFM



Description

- Rack mount fan trays provide a compact, economical solution for cooling in electronic cabinets.
- Fan trays can be positioned at the bottom of an enclosure to force air through the cabinet, at the top to exhaust air out of the cabinet or below specific pieces of equipment for spot cooling.

Standards

- cURus recognized.

Features

- 300, 600 and 900 CFM sizes.
- 115VAC, 50/60Hz.
- 19" panel width mounting.
- Low profile 1.75" (1U) height.
- 600 and 900 CFM units include removable rear support brackets.
- Circuit breaker protected.
- 6 foot 14/3 SJTW cord with molded 3 prong plug.
- Thermally protected, ball bearing fans.
- Integral finger guards above and below fans.
- Shipped fully assembled.
- Available with or without ON/OFF switch.

Finish

- Stocked in textured, black body finish.
- Textured black face panel.

Options

- Contact Hammond for information on:
 - 24" panel width mounting.
 - 230 V version (with IEC 320-C14 INLET).
 - 15 foot cord
 - Optional colors

Climate Control

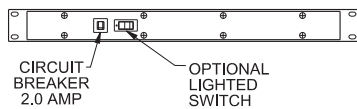
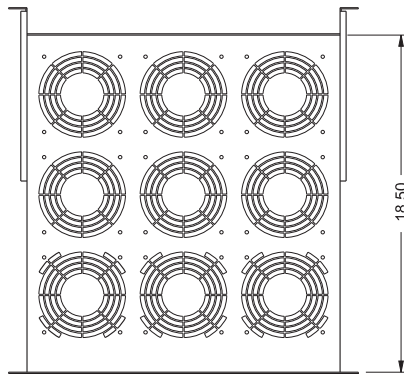

FT900HA1BK

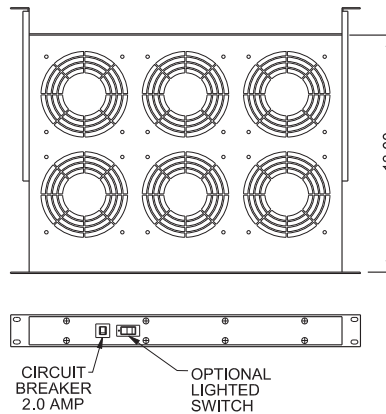

FT600HA1BK

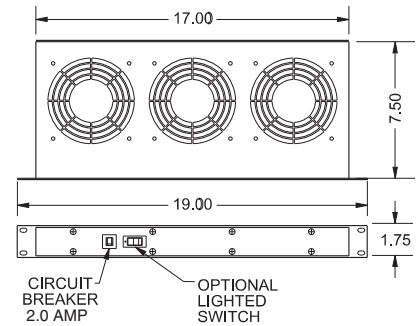

FT300HA1BK

Note: All cad drawings are shown with optional lighted switch. All units are also available without switch - see chart below.

Without Switch Part No.	With Lighted Switch Part No.	CFM	Running Amps	Watts	Panel Width	Case Width	Case Depth	Rear Bracket Depth	
								Min.	Max.
FT300TA1BK	FT300HA1BK	300	0.55	45	19	17.00	7.50	n/a	n/a
FT600TA1BK	FT600HA1BK	600	1.10	90	19	17.00	13.00	2.40	19.20
FT900TA1BK	FT900HA1BK	900	1.70	140	19	17.00	18.50	7.90	24.70