

**HAMMOND
MANUFACTURING™**

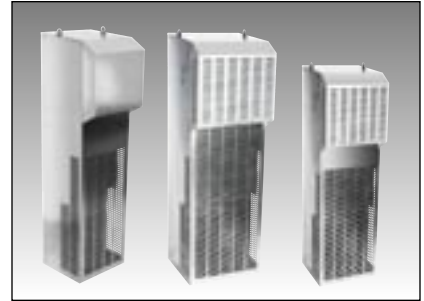
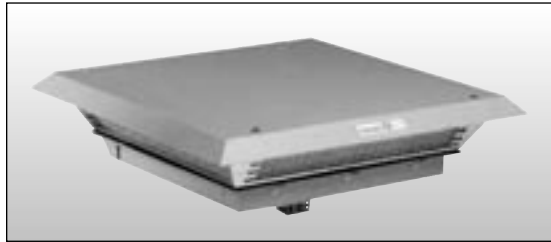

NEW NEMA Type 12 FilterFan®

THE 4TH GENERATION

Hammond Manufacturing Company Limited
394 Edinburgh Rd North, Guelph, ON N1H 1E5
CANADA

Les Fabrications Hammond (Quebec) Inc.
4240 Rue Seré, St. Laurent, Quebec H4T 1A6
CANADA

Hammond Manufacturing Company Inc.
475 Cayuga Rd., Cheektowaga, NY 14225
USA

Tel: (519) 822 - 2960

Fax: (519) 822 - 0715

Tel: (514) 343-9010

Fax: (514) 343-9941

Tel: (716) 630-7030

Fax: (716) 630-7042

World Class, Feature-Laden NEMA Type 12 UL Recognized Filter Fans

Compatible:

Use existing cutout dimensions from current PF series

New Size allows mounting on 10" deep enclosure

Performance:

Maintains high airflow with NEMA Type 12 protection

High service life fluted filter

Voltage range:

24v DC, 115 AC, 230v AC, 460v AC

Pfannenberg PF Series

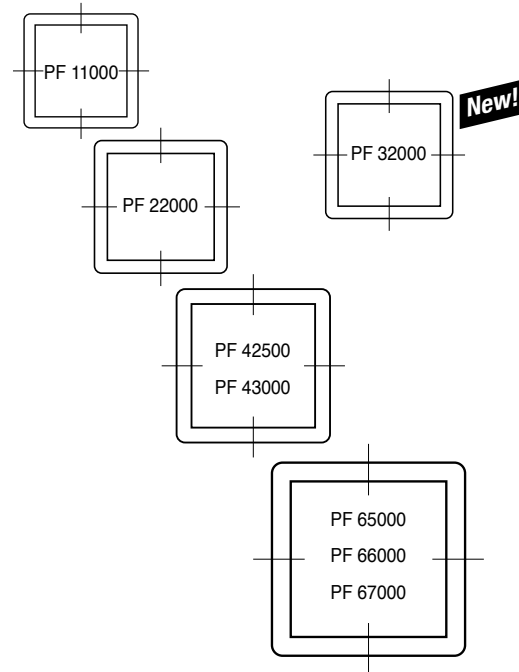

Innovation from a Global Company



Pfannenberg is one of the few companies in the world to develop and manufacture a wide range of industrial thermal products, from facilities both in Europe and the USA.



Hammond HDC inventories products for fast shipments throughout North America in addition to local stock from a broad Authorized Distributor base.

Download your free
Thermal Sizing Software:
www.hamcfg.com/downloads.htm

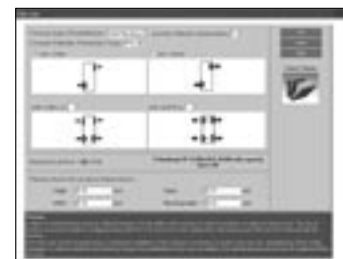

NEMA Type 12 Filterfans®

Features/Benefits:

Patented four-corner “click & fit” system – Enhancing our traditional “click & fit” system, we created an easier to assemble and tighter seal against multiple gauge enclosure sizes.



Special Fluted Filter – This special Type 12 filter increases time between maintenance by three times and allows for greater CFM in dirty environments.

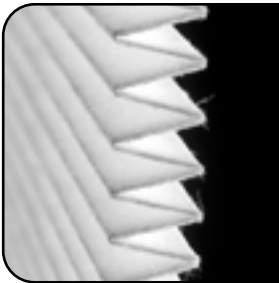

True hardware-free mounting – Our Filterfans do not require any screws to create the pressure on our gasket material to maintain a Type 12 seal against the enclosure. Removing these screws reduce the labor time to mount the Filterfans by greater than 200%.



Easy to change filter – The patented hinge system allows for a quick, hands-free change. This reduces the number of lost and damaged grills when they items are placed on floors and carried away from the machine.



UL tested NEMA Type 12 rating - Our Filterfans are tested by UL to UL 50 Type 12 and NITW2 categories allowing Integrators to maintain the enclosure ratings of the enclosure while maintaining the high CFM ratings of our original Filterfans.



For additional information please visit us at: www.hamcfg.com

Filterfan PF 11000-22000 / Exhaust Filter PFA 10000-20000



Features

- Maintains a UL Tested NEMA Type 12 seal against enclosure
- UL Recognized to UL 508a, category NITW2/8, UL File #E175229
- Patented "Click & Fit" design provides a hardware free installation!
- Plastic made from strong, heat resistant (ABS-FR), UL 94 VO fire approved material
- Fan motor is CSA approved
- OPTIONS: Black grills



Part Number	Voltage	Power	Mating Exhaust Filter	Ship Wt. lbs.
PF11000T12LG	115V	11W	PFA10000	1.5
PF11000T12LG230	230V	11W	PFA10000	1.5
PF11000T12LG24	24V	2W	PFA10000	1.5
PF22000T12LG	115V	20W	PFA20000	2.0
PF22000T12LG230	230V	18W	PFA20000	2.0
PF22000T12LG24	24V	5W	PFA20000	2.0

Airflow data	PF 11000	PF 22000	PFA 1-20000
Filter material	Type 12 filter mat	Type 12 filter mat	Type 12 filter mat
Unimpeded airflow	17 CFM	38 CFM	-
Capacity free-flow	10 W/K	21 W/K	-
Airflow in combination	11 CFM	28 CFM	-
(Filterfan + Exhaust Filter)	(PF 11000 + PFA 10000)	(PF 22000 + PFA 20000)	
Capacity in combination	6 W/K	15 W/K	-
(Filterfan + Exhaust Filter)	(PF 11000 + PFA 10000)	(PF 22000 + PFA 20000)	
Max. static pressure (Airflow = 0 m3/h)	38 Pa	57 Pa	-
Filtration efficiency	88%	91%	88/91%
Filter material grade	G 3 (DIN EN 779)	G 4 (DIN EN 779)	G3/ G4 (DIN EN 779)
Duty cycle	100%	100%	

Technical data	PF 11000	PF 11000	PF 22000	PF 22000	PFA 10000
	AC	DC	AC	DC	PFA 20000
Outside dimensions in mm (height x width x installation depth)	109 x 109 x 62	109 x 109 x 49	145 x 145 x 70	145 x 145 x 64	109 x 109 x 26/ 145 x 145 x 26
Bearing type	sleeve bearings	ball bearings	sleeve bearings	ball bearings	-
Fitting position	vertical	any	vertical	any	-
Construction	housing and guard of sprayed thermoplastic, self-extinguishing, UL 94 VO				
Weight	0.55 kg	0.16 kg	0.7 kg	0.44 kg	0.06 kg / 0.12 kg
Safety protection	in accordance with DIN 31 001				
Color	RAL 7035, Light Gray				
Connection	2 wires, 310 mm long		terminal strip		
System of protection	NEMA Type 12, IP 55 (EN 60 529), when installed as specified				

Filterfan PF 11000-22000 / Exhaust Filter PFA 10000-20000

Airflow data:

PF 11000

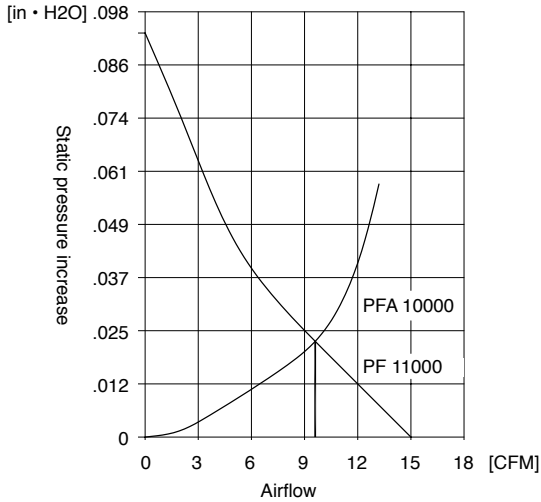

PF 22000

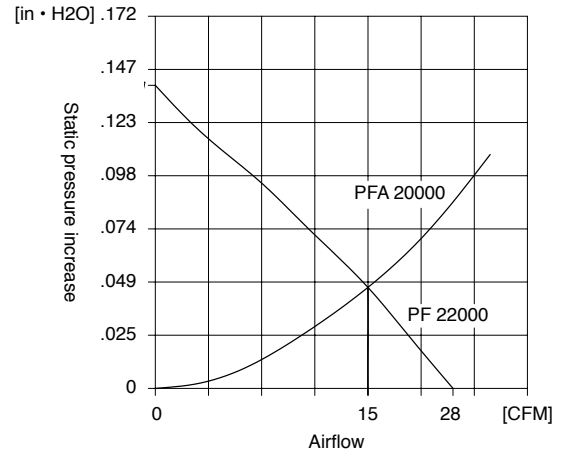

Mechanical data:

PF 11000

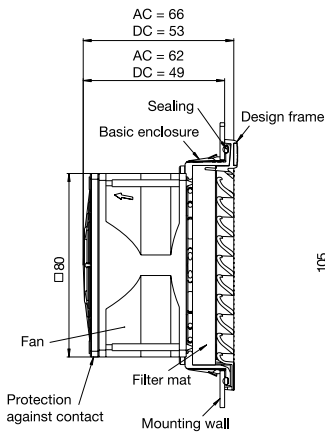

PF 11000 + PFA 10000

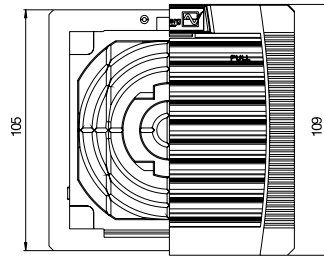

PFA 10000

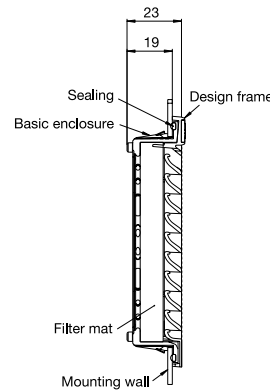

Cutout

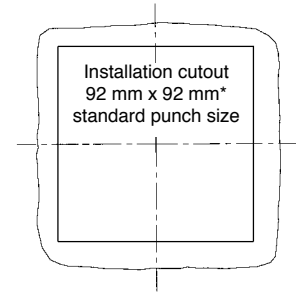

Mechanical data:

PF 22000

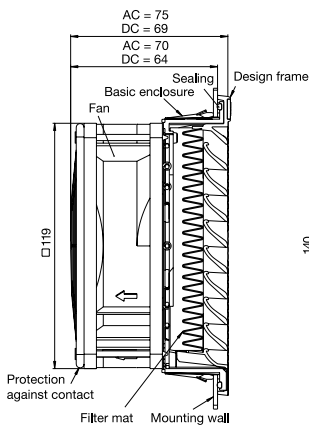

PF 22000 + PFA 20000

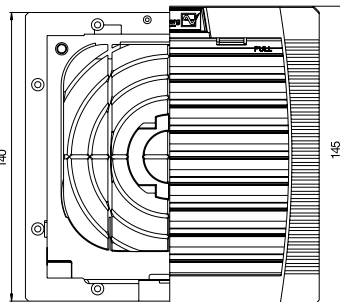

PFA 20000

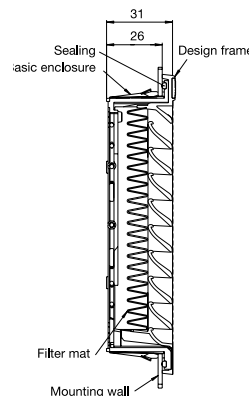

Cutout

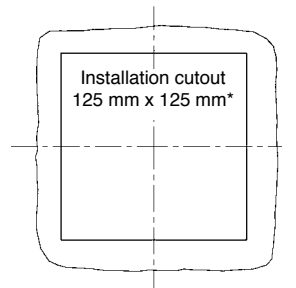

Filterfan PF 32000 / Exhaust Filter PFA 30000



Features

- Maintains a UL Tested NEMA Type 12 seal against enclosure
 - UL Recognized to UL 508a, category NITW2/8, UL File #E175229
 - Patented "Click & Fit" design provides a hardware free installation!
 - Plastic made from strong, heat resistant (ABS-FR), UL 94 VO fire approved material
 - Fan Motor is CSA Approved
- Options: Black Grills



Part Number	Voltage	Power	Mating Exhaust Filter	Ship Wt. lbs.
PF32000T12LG	115V	20W	PFA30000	3.0
PF32000T12LG230	230V	18W	PFA30000	3.0
PF32000T12LG24	24V	5W	PFA30000	3.0

Airflow data	PF 32000	PFA 30000
Filter material	Type 12 filter mat	Type 12 filter mat
Unimpeded airflow	65 CFM	-
Capacity free-flow	37 W/K	-
Airflow in combination	38 CFM	-
(Filterfan + Exhaust Filter)	(PF 32000 + PFA 30000)	-
Capacity in combination	21 W/K	-
(Filterfan + Exhaust Filter)	(PF 32000 + PFA 30000)	-
Max. static pressure (Airflow = 0 m3/h)	61 Pa	-
Filtration efficiency	91%	91%
Filter material grade	G 4 (DIN EN 779)	G 4 (DIN EN 779)
Duty cycle	100%	-

Technical data	PF 32000 AC	PF 32000 DC	PFA 30000
Outside dimensions in mm (height x width x installation depth)	202 x 202 x 87	202 x 202 x 81	202 x 202 x 34
Bearing type	sleeve bearings	ball bearings	-
Fitting position	vertical	any	any
Construction	housing and guard of sprayed thermoplastic, self-extinguishing, UL 94 VO		
Weight	0.87 kg	0.61 kg	0.26 kg
Safety protection	in accordance with DIN 31 001		-
Color	RAL 7035 Light Grey		
Connections	terminal strip	cage clamp	-

Filterfan PF 32000 / Exhaust Filter PFA 30000

Airflow data:

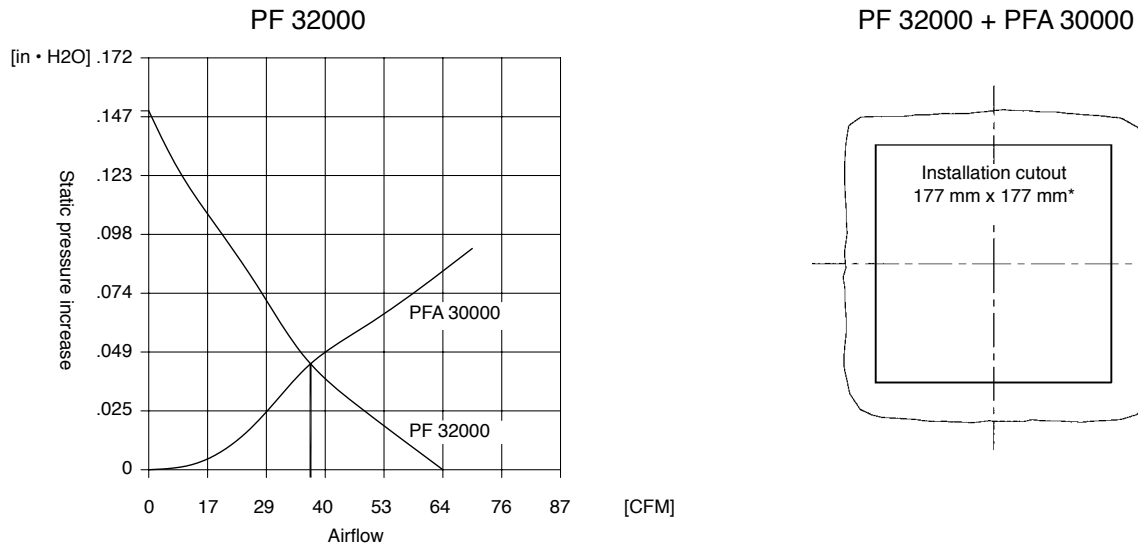

Mechanical data:

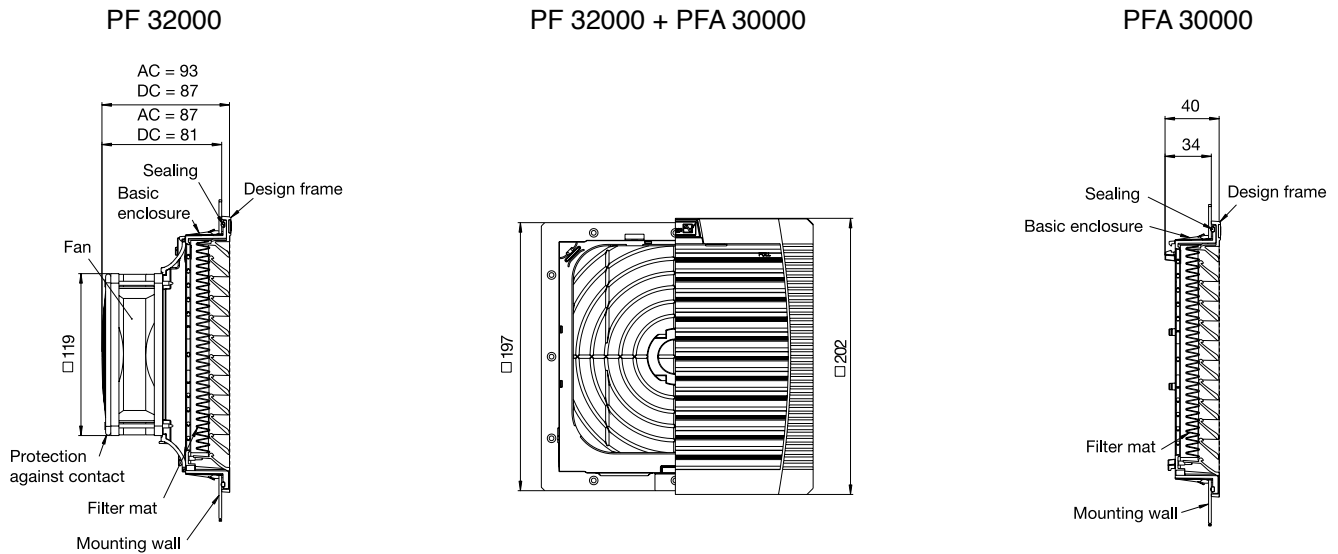

Supplementary data	PF 32000 AC	PF 32000 DC	PFA 30000
Operating temperature		- 15 °C (- 5 °F) to / bis + 55 °C (+ 131 °F)	
Storage temperature		- 20 °C (- 4 °F) to / bis + 70 °C (+ 158 °F)	
Max. relative humidity		90%	
System of protection	NEMA Type 12, IP 55 (EN 60 529), when installed as specified		
Basic Accessories	parts kit filter mat, user manual radiant heater, fan heater, thermostat, hygrostat		
Approvals	UL Recognized		
* Tolerance installation cutout	177 + 1/-0 thickness of material to 2 mm 178 + 1/-0 thickness of material > 2 mm < 3 mm		

Filterfan PF 42500, PF 43000 / Exhaust Filter PFA 40000

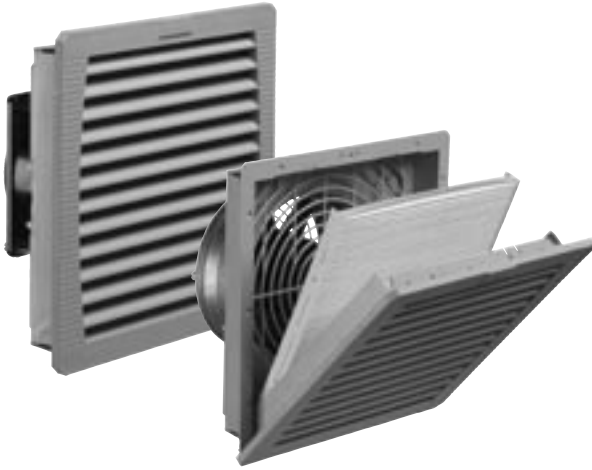

Features

- Maintains a UL Tested NEMA Type 12 seal against enclosure
 - UL Recognized to UL 508a, category NITW2/8, UL File #E175229
 - Patented "Click & Fit" design provides a hardware free installation!
 - Plastic made from strong, heat resistant (ABS-FR), UL 94 VO fire approved material
 - Fan Motor is CSA Approved
- Options: Black Grills



Part Number	Voltage	Power	Mating Exhaust Filter	Ship Wt. lbs.
PF42500T12LG	115V	20W	PFA40000	4.0
PF42500T12LG230	230V	18W	PFA40000	4.0
PF42500T12LG24	24V	5W	PFA40000	4.0
PF43000T12LG	115V	40W	PFA40000	5.0
PF43000T12LG230	230V	39W	PFA40000	5.0
PF43000T12LG24	24V	12W	PFA40000	5.0

Airflow data	PF 42500	PF 43000	PFA 40000
Filter material	NEMA Type 12 Filtermat	NEMA Type 12 Filtermat	NEMA Type 12 Filtermat
Unimpeded airflow	94 CFM	169 CFM	-
Capacity free-flow	53 W/K	188 W/K	-
Airflow in combination	67 CFM	142 CFM	-
(Filterfan + Exhaust Filter)	(PF 42500 + PFA 40000)	(PF 43000 + PFA 40000)	
Capacity in combination	38 W/K	69 W/K	-
(Filterfan + Exhaust Filter)	(PF 43000 + PFA 40000)	(PF 43000 + PFA 40000)	
Max. static pressure (Airflow = 0 m ³ /h)	49 Pa	112 Pa	-
Filtration efficiency	91%	91%	91%
Filter material grade	G 4 (DIN EN 779)	G 4 (DIN EN 779)	G 4 (DIN EN 779)
Duty cycle	100%	100%	-

Technical data	PF 42500		PF 43000		PFA 40000
	AC	DC	AC	DC	
Outside dimensions in mm (height x width x installation depth)	252 x 252 x 97		252 x 252 x 113		252 x 252 x 38
Bearing type / Lagerart	ball bearings		ball bearings		-
Fitting position / Einbaulage	any, horizontal airflow preferred				any
Construction	housing and guard of sprayed thermoplastic, self-extinguishing, UL 94 VO				
Weight	1.18 kg		1.67 kg		0.46 kg
Safety protection	in accordance with DIN 31 001				
Color	RAL 7035, Light Grey				
Connections / Anschlussart	cage clamp		cage clamp		-

Filterfan PF 42500, PF 43000 / Exhaust Filter PFA 40000

Airflow data:

PF 42500 / PF 43000

PF 42500, PF 43000 + PFA 40000

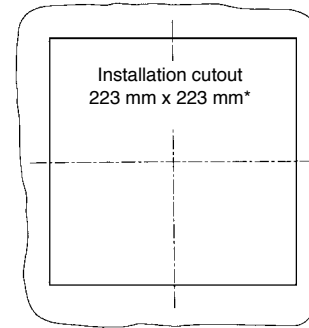
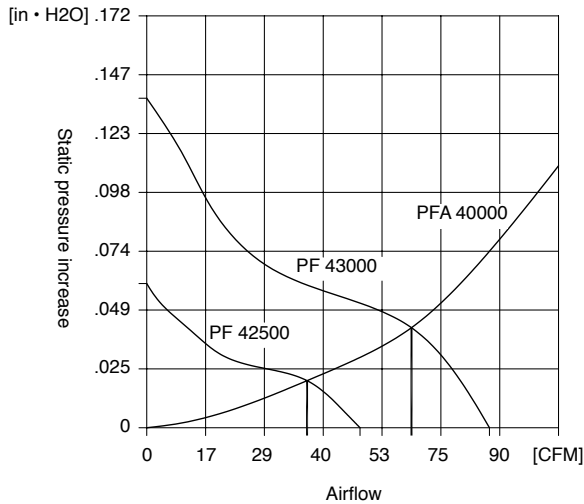

Mechanical data:

PF 42500, PF 43000

PF 42500 PF 43000, PFA 40000

PFA 40000

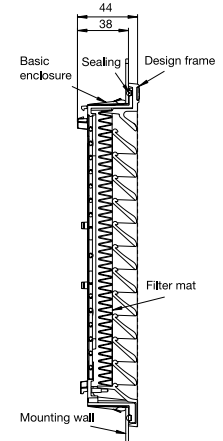
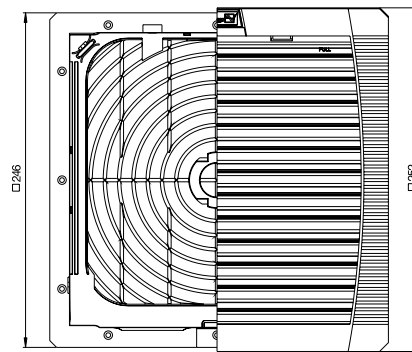
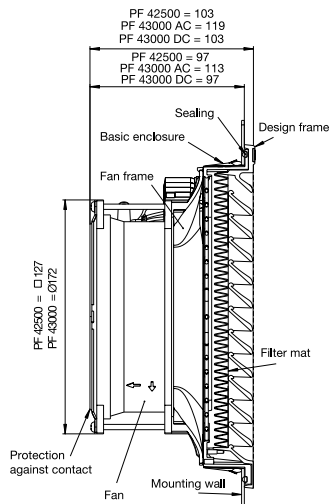

Supplementary data	PF 42500	PF 43000	PFA 40000
Operating temperature	- 15 °C (- 5 °F) to / bis + 55 °C (+ 131 °F)		
Storage temperature	- 20 °C (- 4 °F) to / bis + 70 °C (+ 158 °F)		
Max. relative humidity	90%		
System of protection	NEMA Type 12, IP 55 (EN 60 529), when installed as specified		
Basic Accessories	parts kit filter mat, user manual radiant heater, fan heater, thermostat, hygrostat		
Approvals	UL Recognized		
* Tolerance installation cutout	177 + 1/-0 thickness of material to 2 mm 178 + 1/-0 thickness of material > 2 mm < 3 mm		

Filterfan PF 65000, PF 66000, PF 67000 / Exhaust Filter PFA 60000



Features

- Maintains a UL Tested NEMA Type 12 seal against enclosure
 - UL Recognized to UL 508a, category NITW2/8, UL File #E175229
 - Patented "Click & Fit" design provides a hardware free installation!
 - Plastic made from strong, heat resistant (ABS-FR), UL 94 VO fire approved material
 - Fan Motor is CSA Approved
- Options: Black Grills



Part Number	Voltage	Power	Mating Exhaust Filter	Ship Wt. lbs.
PF65000T12LG	115V	90W	PFA60000	7.5
PF65000T12LG230	230V	150W	PFA60000	7.5
PF66000T12LG	115V	160W	PFA60000	8.0
PF66000T12LG230	230V	150W	PFA60000	8.0
PF67000T12LG	115V	95W	PFA60000	8.0
PF67000T12LG230	230V	214W	PFA60000	8.0

Airflow data	PF 65000	PF 66000	PF 67000	PFA 60000
Filter material	Type 12 Filtermat	Type 12 Filtermat	Type 12 Filtermat	Type 12 Filtermat
Unimpeded airflow	297 CFM	462 CFM	560 CFM	
Capacity free-flow	IP 54: 160 W/K / 160 W/K	IP 54: 213 W/K / 218 W/K	IP 54: 282 W/K / 292 W/K	-
	IP 55: 168 W/K / 168 W/K	IP 55: 257 W/K / 262 W/K	IP 55: 308 W/K / 317 W/K	
Airflow in combination (Filterfan + Exhaust Filter) (PF 65000 + PFA 60000)	230 CFM	295 CFM	368 CFM	-
Capacity in combination (Filterfan + Exhaust Filter) (PF 65000 + PFA 60000)	127 W/K	167 W/K	208 W/K	-
Max. static pressure (Airflow = 0)	74 Pa	134 Pa	187 Pa	-
Filtration efficiency	91 %	91 %	91 %	91 %
Filter material grade	G 4 (DIN EN 779)	G 4 (DIN EN 779)	G 4 (DIN EN 779)	G 4 (DIN EN 779)
Duty cycle	100%	100%	100%	-

Technical data	PF 65000	PF 66000	PF 67000	PFA 60000
Outside dimensions in mm (height x width x installation depth)	320 x 320 x 150	320 x 320 x 150	320 x 320 x 150	320 x 320 x 39
Bearing type	ball bearings	ball bearings	ball bearings	-
Fitting position		any, horizontal airflow preferred	any	
Construction	housing and guard of sprayed thermoplastic, self-extinguishing, UL 94 VO			
Weight	3.2 kg	3.2 kg	3.7 kg	0.7 kg
Safety protection	in accordance with DIN 31 001			
Color	RAL 7035, Light Grey			
Connections	cage clamp	cage clamp	cage clamp	-

Filterfan PF 65000, PF 66000, PF 67000 / Exhaust Filter PFA 60000

Airflow data:

PF 65000 / PF 66000 / PF 67000

PF 65000, PF 66000, PF 67000 + PFA 60000

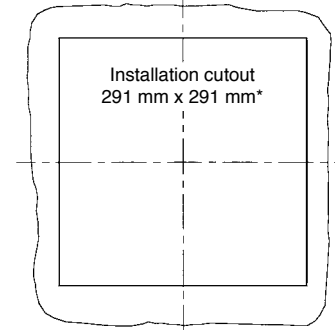
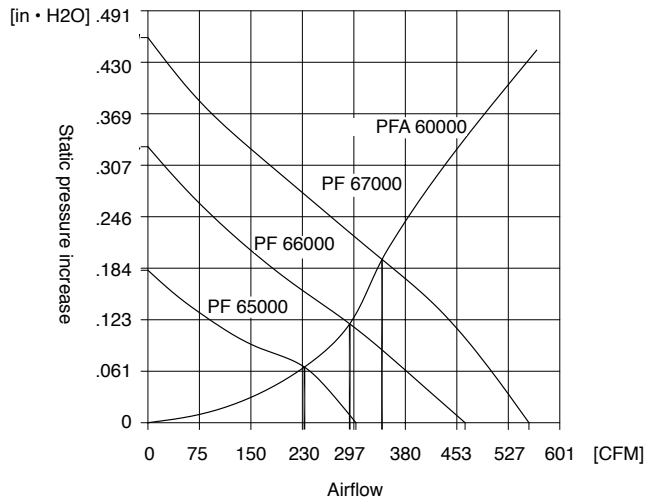

Mechanical data:

PF 65000, PF 66000,
PF 67000

PF 65000, PF 66000,
PF 67000 + PFA 60000

PFA 60000

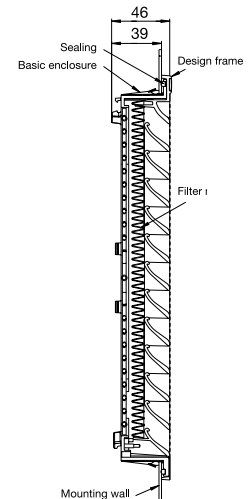
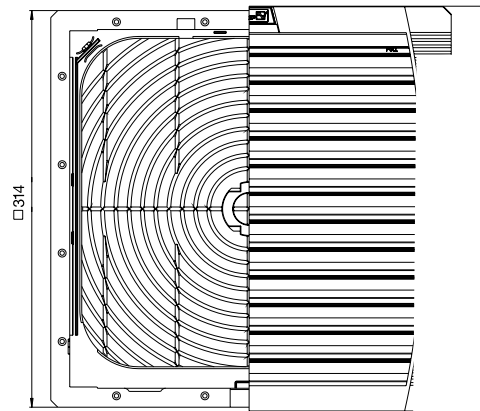
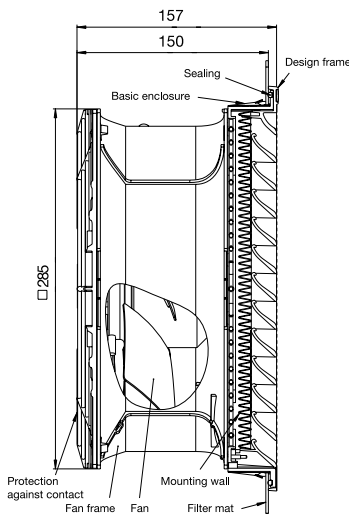

Supplementary data	PF 65000	PF 66000	PF 67000
Operating temperature	- 15 °C (- 5 °F) to / bis + 55 °C (+ 131 °F)		
Storage temperature	- 20 °C (- 4 °F) to / bis + 70 °C (+ 158 °F)		
Max. relative humidity	90%		
System of protection	NEMA Type 12, IP 55 (EN 60 529), when installed as specified		
Basic Accessories	parts kit filter mat, user manual radiant heater, fan heater, thermostat, hygrostat		
Approvals	UL Recognized		
* Tolerance installation cutout	177 + 1/-0 thickness of material to 2 mm 178 + 1/-0 thickness of material > 2 mm < 3 mm		

Filterfan PTF 60500, PTF 60700, PTF 61000 / Exhaust Filter PTFA 60000



Features

- Maintains a NEMA 12 seal against enclosure
- UL Recognized to UL 508a, category NITW2/8, UL File #E175229
- Patented "Click & Fit" design provides a hardware free installation!
- Metal Pagoda Cover for rugged environments, easily painted to match machine color
- Fan Motor is CSA Approved



Part Number	Voltage	Power	Mating Exhaust Filter	Ship Wt. lbs.
PTF60500LG	115V	24W	PFA60000	14
PTF60500LG230	230V	24W	PFA60000	14
PTF60700LG	115V	90W	PFA60000	14
PTF60700LG230	230V	80W	PFA60000	14
PTF61000LG	115V	170W	PFA60000	15
PTF61000LG230	230V	150W	PFA60000	15

Airflow data	PTF 60500	PTF 60700	PTF 61000	PTFA 60000
Filter material	NEMA 12 Filtermat	NEMA 12 Filtermat	NEMA 12 Filtermat	NEMA 12 Filtermat
Unimpeded airflow	226 CFM	356 CFM	485 CFM	-
Capacity free-flow	113 W/K	177 W/K	242 W/K	-
Airflow in combination	149 CFM	227 CFM	304 CFM	-
(Filterfan + Exhaust Filter) (PTF 60500 + PFA 60000)		(PTF 60700 + PFA 60000)	(PTF 61000 + PFA 60000)	
Capacity in combination	74 W/K	113 W/K	152 W/K	-
(Filterfan + Exhaust Filter) (PTF 60500 + PFA 60000)		(PTF 60700 + PFA 60000)	(PTF 61000 + PFA 60000)	
Max. static pressure (Airflow = 0)	71 Pa	88 Pa	158 Pa	-
Filtration efficiency	81 %	81 %	81 %	-
Filter material grade	G 3 (DIN EN 779)	G 3 (DIN EN 779)	G 3 (DIN EN 779)	-
Duty cycle	100%	100%	100%	-

Technical data	PTF 60500	PTF 60700	PTF 61000	PTFA 60000
Outside dimensions in mm (height x width x installation depth)	125 x 430 x 430 x 50	140 x 470 x 470 x 50	140 x 470 x 470 x 50	-
Bearing type	ball bearings	ball bearings	ball bearings	-
Fitting position	horizontal	horizontal	horizontal	any
Construction	metal chassis cover powder coated, snapin plastic housing			
Weight	5.5 kg	5.8 kg	6.0 kg	3.1 kg
Safety protection	in accordance with DIN 31 001			
Color	RAL 7035 (Light Grey)			
Connections	terminal strip	terminal strip	terminal strip	-

Filterfan PTF 60500, PTF 60700, PTF 61000 / Exhaust Filter PTFA 60000

Airflow data:

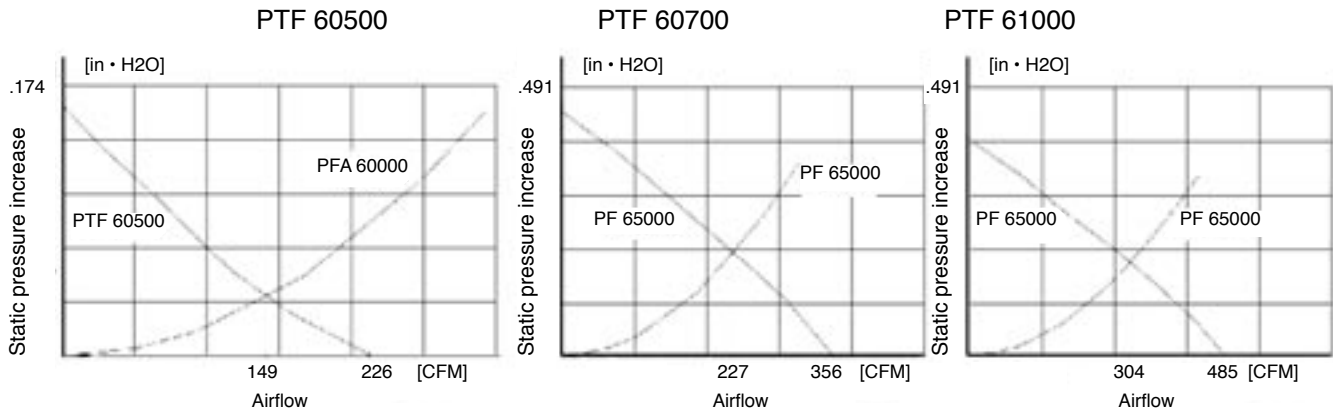

Mechanical data:

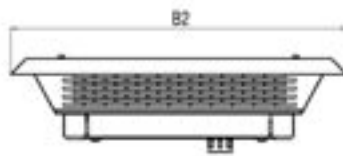
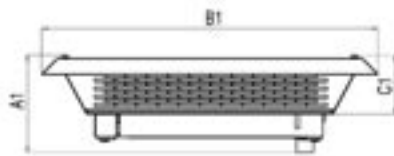

Cutout

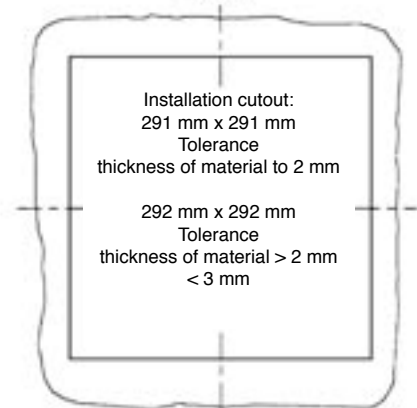

	PTF 60500	PTF 60700	PTF 61000	PTFA 60000
A1	125	140	140	110*
B1/B2	430	470	470	430
C1	75	90	90	75

Airflow data:	PTFA 60000
Filter material	P 300
Filtration efficiency	81%
Filter material grade (DIN EN 779)	G 3

Technical data:	PFTA 60000
Outside dimensions in mm (Height x Width x Depth x Installation depth)	110 x 430 x 430 x 35
Construction	metal chassis, cover powder-coated; snap-in body of sprayed thermoplastic (ABS-FR) self-extinguishing, UL 94 VO
Weight	3.1 kg
Safety protection	in accordance with DIN 31 001
Colour	RAL 7035, RAL 7032, other colours on request

Supplementary data:	PFTA 60000
Operating temperature	-10 C (+14 F) to +55 C (+131 F)
Storage temperature	-20 C (-4 F) to +70 C (+158 F)
Max. relative humidity	90%
System of protection	IP 33, IP 54 (EN 60 529), when installed as specified
Accessories	radiant heater, fan heater, thermostat, see Thermal Management
Tolerance installation cutout	291 thickness of material to 2 mm, 292 thickness of material > 2 mm < 3mm
Approvals	pending

Accessory Products

Exhaust Filters:



Part Number	Filtration Efficiency %
PFA10000	88%
PFA20000	91%
PFA30000	91%
PFA40000	91%
PFA60000	91%

Standard grill color: RAL 7035 Light Grey



Features

- Maintains a UL Tested NEMA Type 12 seal against enclosure
- UL Recognized to UL 508a, category NITW2/8, UL File #E175229
- Patented "Click & Fit" design provides a hardware free installation!
- Plastic made from strong, heat resistant (ABS-FR) UL 94 VO fire approved material
- Options: Black Grills

Replacement Filters:

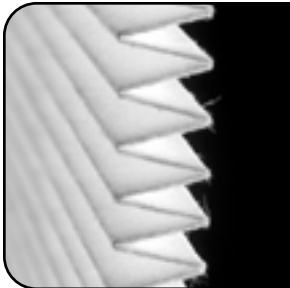

Part Number	Use with 4th Gen FF
PFF10000	PF/PFA 1XXXX
PFF20000	PF/PFA 2XXXX
PFF30000	PF/PFA 3XXXX
PFF40000	PF/PFA 4XXXX
PFF60000	PF/PFA 6XXXX

Features

- Special patent pending fluted filter design increases the time between maintenance by 3X.
- Allows for greater CFM in dirty environments
- Sold in Packs of 5.

Thermostats:



Features

- Mechanical bi-metallic thermostat
- Suitable for Filterfans or Heaters
- Available in Fahrenheit or Celsius



Part Number	Description	Switching Capacity
SKT011419NO	Normally Open, F	15A AC 120V, 10A AC 250V
SKT011419NO-C	Normally Open, C	15A AC 120V, 10A AC 250V
SKT011409NC	Normally Closed, F	15A AC 120V, 10A AC 250V
SKT011409NC-C	Normally Closed, C	15A AC 120V, 10A AC 250V

Cooling Unit Selection Guide



NEMA Type 12 Indoor - Side Mount:

	DTS3341A230LG	DTS3541A230LG	DTS3641A230LG
	DTS3341A460LG	DTS3541A460LG	DTS3641A460LG
Cooling Capacity (Btu/h*)	12-14000	16-18000	20-24000
External Airflow (CFM)	991	1480	1612
Internal Airflow (CFM)	788	788	1612
NEMA Type Rating	Type 12	Type 12	Type 12
UL Listed or Recognized	Listed	Listed	Listed
Connection Type	Permanent	Permanent	Permanent

Features

- Maintains a UL Tested NEMA Type 12 seal against enclosure
- UL Listed to UL 484, UL File #SA10300, CE approved
- Long internal airpath captures heat above components and provides cool air below!
- Powder coated steel cover for rugged environments, easily painted to match machine
- Uses Standard Control logic board
- Condensate Management built into design of unit



NEMA Type 3R/4 Outdoor:

	DTS3361A230N3LG	DTS3561A230N3LG	DTS3661A230N3LG
	DTS3361A460N3LG	DTS3561A460N3LG	DTS3661A460N3LG
Cooling Capacity (Btu/h*)	12-14000	16-18000	22-24000
External Airflow (CFM)	991	1480	1612
Internal Airflow (CFM)	788	788	1612
NEMA Type Rating	Type 3R/4	Type 3R/4	Type 3R/4
UL Listed or Recognized	Listed	Listed	Listed
Connection Type	Permanent	Permanent	Permanent

Features

- Maintains a UL Tested NEMA Type 3R/4 or 4/4X seal against enclosure
- UL Listed to UL 484, UL File #SA10300, CE approved
- Long internal airpath captures heat above components and provides cool air below!
- Powder coated steel cover for rugged environments, easily painted to match machine
- Uses Standard Control logic board and sump heater standard
- Condensate Management built into design of unit

Options: Low ambient package, Built-In enclosure heater

NEMA Type 4/4X Outdoor/Washdown:

	DTS3381A230N4SS	DTS3581A230N4SS	DTS3681A230N4SS
	DTS3381A460N4SS	DTS3581A460N4SS	DTS3681A460N4SS
Cooling Capacity (Btu/h*)	12-14000	16-18000	20-24000
External Airflow (CFM)	991	1480	1612
Internal Airflow (CFM)	788	788	1612
NEMA Type Rating	Type 4/4X	Type 4/4X	Type 4/4X
UL Listed or Recognized	Listed	Listed	Listed
Connection Type	Permanent	Permanent	Permanent

