



# HAMMOND MANUFACTURING™



## ***HME Series Modular Enclosure System***

*One Door Cabinets  
Two Door Cabinets  
Flange Disconnect Cabinets  
Easy Install Panel  
Grid Mounting System  
Cooling Products  
Accessories*

**Modular Enclosures**



Doors feature easy to remove hinges that can be reversed. Seamless foam-in-place gasket keeps dust out.



Frame surfaces feature square (for cage nut) and round holes at 25mm centers for convenient mounting (like optional light kits as shown).



Overhanging top panel provides added protection from falling dirt and dust. Knife-edge lip design around door opening allows for superior seal. Heavy duty lifting eyes in 4 corners provide balanced loading when systems moved.



Multiple mounting opportunities using standard galvanized inner panel and optional wide and narrow grid straps.



Standard black escutcheon features double bit insert. Optional light gray heavy duty lifting handle has key locking or push button option.



Door frame provides rigidity and yet another easy mounting location. Ground studs on frame and all doors/panels.



The HME Modular Enclosure System provides a vast array of features and advantages supported by Hammond's reliable quality and service.

Base configuration includes 14 gauge steel frame, front door, rear cover, top panel, bottom gland plate panel, easy-install inner mounting panel and 4 lifting eyebolts. Finished in RAL 7035 light gray textured powder paint.

Typical options include plinths, side panels, various handles and cooling.



Two door cabinets feature overlapping doors where the 2nd door is held firmly in place with top and bottom latches.



In ganged cabinets, optional bridge panel can be easily installed to provide a continuous mounting surface.



Optional 19" rack mounting rails can be used in 600mm and 800mm wide cabinets. For 800mm wide cabinet, adaptor kit required.



Optional plinth consists of corner blocks (shown above) and panels on all 4 sides. Compatible with optional leveling feet.

## HME Easy-install mounting panel



Place the panel supports at any desired point along the strut channels



Secure bottom panel supports and upper panel mounting brackets into place. Upper panel mounting brackets feature a heavy duty collar stud. Notches in strut provide locating guidance.



Inner panel slides easily along bottom strut channels and hooks over bottom panel supports.



Continue to push top of panel until collar studs protrude through panel mounting holes.



Secure panel to studs.



Optional 19" rack mounting rails can be mounted at any depth in the cabinet when combined with grid straps.



Gland bottom panels allow for convenient and simple cable entry. Gap space is adjustable. Plates can be removed with inner panel installed.

## Why use HME Series from Hammond Mfg?

- User-friendly design features with Hammond quality you can trust.
- Low-run modification services (custom configurations, special paint colors, cutouts, windows, etc.) ensure you get exactly what YOU want.
- Local design and manufacturing ensure faster turnaround and the comfort that your critical answers and parts are just a quick phone call away.

**Quality Products.  
Service Excellence**

## HME Series

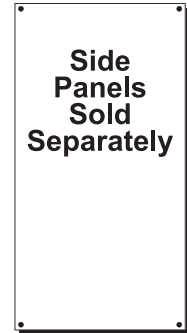

### Application

- The HME product line provides users with a rugged housing for industrial control and operator interface in industrial environments.
- Modular design permits joining of units together for large scale and mixed use applications.
- Frame's 25mm hole pattern provides extensive component and accessory mounting flexibility.
- A broad range of industry standard sizes are offered.

### Standards

- UL 508 Type 12
- CSA Type 12
- **Complies with**
  - NEMA Type 12
  - IEC 60529 IP54

### Configuration

- Frame
- Removable solid top panel
- Lifting eyebolts (4)
- Removable bottom panel w/gland plates
- Solid front door with door frame
- Removable rear cover panel
- Inner mounting panel

### Construction

- Formed 14 gauge steel.
- Fully welded frame with 25mm hole pattern for superior mounting flexibility.
- Seamless foam in place gasket.
- Reinforced eyebolts are provided for easy enclosure lifting.
- Frames can be joined together with an optional joining kit.
- Doors can be easily interchanged, removed and/or reversed.
- Door opening 135°.
- Optional formed 14 gauge steel side panels are sold separately (in pairs).
- Bonding and grounding studs are provided for all doors and panels.

### Finish

- Phosphatized and finished in RAL 7035 light gray powder coating.
- Inner panel is unpainted galvanized 12 gauge steel.

### Accessories

- 19" mounting rails
- Cooling - ACs
- Cooling - fans
- Door shelf
- Frame joining kit
- Grid mounting system
- Handles and inserts
- Interlock system
- Leveling feet
- Light kit and accessories
- Literature pocket
- Panel - Bridge
- Panel - Barrier
- Swing Panel
- Swing Frame
- Plinth
- Side panels
- Tamper resistant screws
- Top mount cable module



# Modular Enclosures

## HME Series

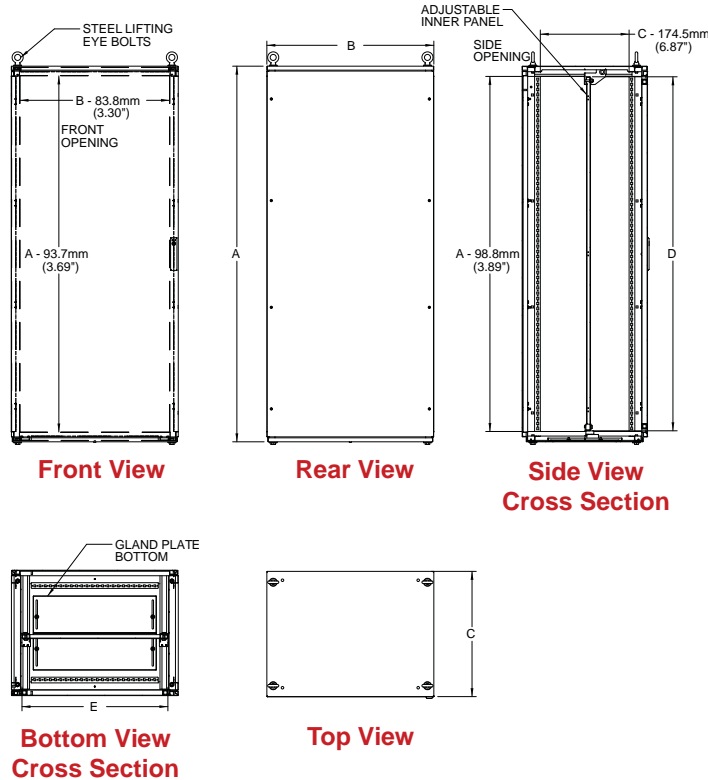

Part Number	Overall Dimensions			Panel Dimensions		
		A	B	C	D	E
HME1465	mm	1400	600	500	1296	499
	inch	55.12	23.62	19.69	51.03	19.65
HME1466	mm	1400	600	600	1296	499
	inch	55.12	23.62	23.62	51.03	19.65
HME1468	mm	1400	600	800	1296	499
	inch	55.12	23.62	31.5	51.03	19.65
HME1485	mm	1400	800	500	1296	699
	inch	55.12	31.5	19.69	51.03	27.52
HME1486	mm	1400	800	600	1296	699
	inch	55.12	31.5	23.62	51.03	27.52
HME1488	mm	1400	800	800	1296	699
	inch	55.12	31.5	31.5	51.03	27.52
HME1665	mm	1600	600	500	1496	499
	inch	62.99	23.62	19.69	58.9	19.65
HME1666	mm	1600	600	600	1496	499
	inch	62.99	23.62	23.62	58.9	19.65
HME1668	mm	1600	600	800	1496	499
	inch	62.99	23.62	31.5	58.9	19.65
HME1685	mm	1600	800	500	1496	699
	inch	62.99	31.5	19.69	58.9	27.52
HME1686	mm	1600	800	600	1496	699
	inch	62.99	31.5	23.62	58.9	27.52
HME1688	mm	1600	800	800	1496	699
	inch	62.99	31.5	31.5	58.9	27.52
HME1864	mm	1800	600	400	1696	499
	inch	70.87	23.62	15.75	66.77	19.65
HME1865	mm	1800	600	500	1696	499
	inch	70.87	23.62	19.69	66.77	19.65
HME1866	mm	1800	600	600	1696	499
	inch	70.87	23.62	23.62	66.77	19.65
HME1868	mm	1800	600	800	1696	499
	inch	70.87	23.62	31.5	66.77	19.65
HME1884	mm	1800	800	400	1696	699
	inch	70.87	31.5	15.75	66.77	27.52
HME1885	mm	1800	800	500	1696	699
	inch	70.87	31.5	19.69	66.77	27.52
HME1886	mm	1800	800	600	1696	699
	inch	70.87	31.5	23.62	66.77	27.52
HME1888	mm	1800	800	800	1696	699
	inch	70.87	31.5	31.5	66.77	27.52
HME18104	mm	1800	1000	400	1696	899
	inch	70.87	39.37	15.75	66.77	35.4
HME18105	mm	1800	1000	500	1696	899
	inch	70.87	39.37	19.69	66.77	35.4

Part Number	Overall Dimensions			Panel Dimensions		
		A	B	C	D	E
HME18106	mm	1800	1000	600	1696	899
	inch	70.87	39.37	23.62	66.77	35.4
HME18108	mm	1800	1000	800	1696	899
	inch	70.87	39.37	31.5	66.77	35.4
HME2045	mm	2000	400	500	1896	299
	inch	78.74	15.75	19.69	74.65	11.77
HME2064	mm	2000	600	400	1896	499
	inch	78.74	23.62	15.75	74.65	19.65
HME2065	mm	2000	600	500	1896	499
	inch	78.74	23.62	19.69	74.65	19.65
HME2066	mm	2000	600	600	1896	499
	inch	78.74	23.62	23.62	74.65	19.65
HME2068	mm	2000	600	800	1896	499
	inch	78.74	23.62	31.5	74.65	19.65
HME2084	mm	2000	800	400	1896	699
	inch	78.74	31.5	15.75	74.65	27.52
HME2085	mm	2000	800	500	1896	699
	inch	78.74	31.5	19.69	74.65	27.52
HME2086	mm	2000	800	600	1896	699
	inch	78.74	31.5	23.62	74.65	27.52
HME2088	mm	2000	800	800	1896	699
	inch	78.74	31.5	31.5	74.65	27.52
HME20106	mm	2000	1000	600	1896	899
	inch	78.74	39.37	23.62	74.65	35.4
HME20108	mm	2000	1000	800	1896	899
	inch	78.74	39.37	31.5	74.65	35.4
HME2246	mm	2200	400	600	2096	299
	inch	86.62	15.75	23.62	82.52	11.77
HME2265	mm	2200	600	500	2096	499
	inch	86.62	23.62	19.69	82.52	19.65
HME2266	mm	2200	600	600	2096	499
	inch	86.62	23.62	23.62	82.52	19.65
HME2285	mm	2200	800	500	2096	699
	inch	86.62	31.5	19.69	82.52	27.52
HME2286	mm	2200	800	600	2096	699
	inch	86.62	31.5	23.62	82.52	27.52
HME2288	mm	2200	800	800	2096	699
	inch	86.62	31.5	31.5	82.52	27.52
HME22105	mm	2200	1000	500	2096	899
	inch	86.62	39.37	19.69	82.52	35.4
HME22106	mm	2200	1000	600	2096	899
	inch	86.62	39.37	23.62	82.52	35.4

Technical references and CAD downloads available at [www.hammondmfg.com](http://www.hammondmfg.com)

All dimensions in inches unless specified otherwise

**Quality Products. Service Excellence.**

## HMET Series

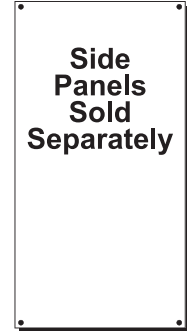

### Application

- The HMET 2 door product line provides users with a rugged housing for industrial control and operator interface in industrial environments.
- Modular design permits joining of units together for large scale and mixed use applications.
- Frame's 25mm hole pattern provides extensive component and accessory mounting flexibility.
- A broad range of industry standard sizes are offered.

### Standards

- UL 508 Type 12
- CSA Type 12
- **Complies with**
  - NEMA Type 12
  - IEC 60529 IP54

### Configuration

- Frame
- Removable solid top panel
- Lifting eyebolts (4)
- Removable bottom panel w/gland plates
- Two overlapping solid front doors with door frames
- Two removable rear cover panels with removable rear center post
- Full width inner mounting panel

### Construction

- Formed 14 gauge steel.
- Fully welded frame with 25mm hole pattern for superior mounting flexibility.
- Seamless foam in place gasket.
- Reinforced eyebolts are provided for easy enclosure lifting.
- Frames can be joined together with an optional joining kit.
- Doors can be easily interchanged, removed and/or reversed.
- Door opening 135°.
- Optional formed 14 gauge steel side panels are sold separately (in pairs).
- Bonding and grounding studs are provided for all doors and panels.

### Finish

- Phosphatized and finished in RAL 7035 light gray powder coating.
- Inner panel is unpainted galvanized 12 gauge steel.

### Accessories

- 19" mounting rails
- Cooling - ACs
- Cooling - fans
- Door shelf
- Frame joining kit
- Grid mounting system
- Handles and inserts
- Interlock system
- Leveling feet
- Light kit and accessories
- Literature pocket
- Panel - Bridge
- Panel - Barrier
- Plinth
- Side panels
- Tamper resistant screws
- Top mount cable module

# Modular Enclosures

## HMET Series

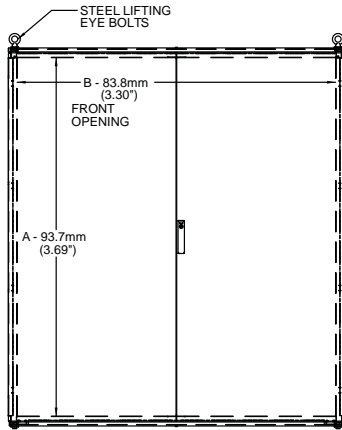

**Front View**

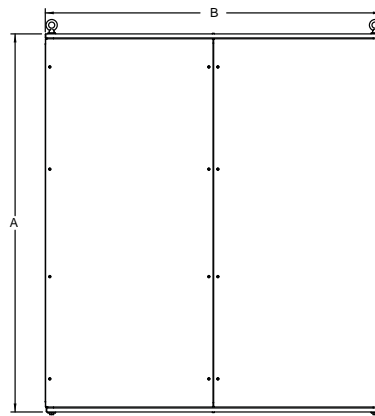

**Rear View**

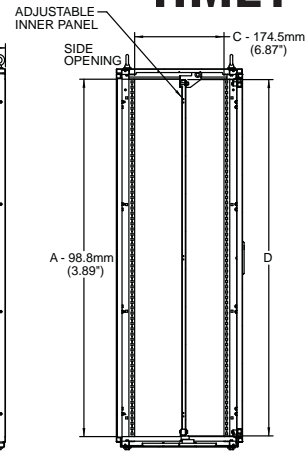

**Side View Cross Section**

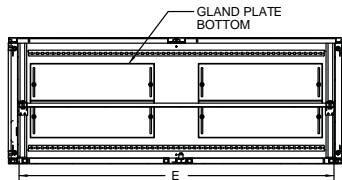

**Bottom View Cross Section**

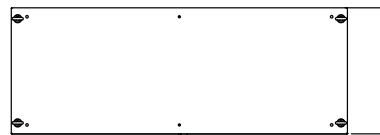

**Top View**

Part Number	Overall Dimensions			Panel Dimensions		
	A	B	C	D	E	
HMET14125	mm	1400	1200	500	1296	1099
	inch	55.12	47.25	19.69	51.03	43.27
HMET14126	mm	1400	1200	600	1296	1099
	inch	55.12	47.25	23.62	51.03	43.27
HMET14128	mm	1400	1200	800	1296	1099
	inch	55.12	47.25	31.50	51.03	43.27
HMET16125	mm	1600	1200	500	1496	1099
	inch	62.99	47.25	19.69	58.90	43.27
HMET16126	mm	1600	1200	600	1496	1099
	inch	62.99	47.25	23.62	58.90	43.27
HMET16128	mm	1600	1200	800	1496	1099
	inch	62.99	47.25	31.50	58.90	43.27
HMET1886	mm	1800	800	600	1696	699
	inch	70.87	31.50	23.62	66.77	27.52
HMET1885	mm	1800	800	500	1696	699
	inch	70.87	31.50	19.69	66.77	27.52
HMET18104	mm	1800	1000	400	1696	899
	inch	70.87	39.37	15.75	66.77	35.40
HMET18124	mm	1800	1200	400	1696	1099
	inch	70.87	47.25	15.75	66.77	43.27
HMET18125	mm	1800	1200	500	1696	1099
	inch	70.87	47.25	19.69	66.77	43.27
HMET18126	mm	1800	1200	600	1696	1099
	inch	70.87	47.25	23.62	66.77	43.27
HMET18128	mm	1800	1200	800	1696	1099
	inch	70.87	47.25	31.50	66.77	43.27
HMET18164	mm	1800	1600	400	1696	1499
	inch	70.87	62.99	15.75	66.77	59.02
HMET18165	mm	1800	1600	500	1696	1499
	inch	70.87	62.99	19.69	66.77	59.02
HMET18166	mm	1800	1600	600	1696	1499
	inch	70.87	62.99	23.62	66.77	59.02
HMET18168	mm	1800	1600	800	1696	1499
	inch	70.87	62.99	31.50	66.77	59.02
HMET18184	mm	1800	1800	400	1696	1699
	inch	70.87	70.87	15.75	66.77	66.89

Part Number	Overall Dimensions			Panel Dimensions		
	A	B	C	D	E	
HMET18185	mm	1800	1800	500	1696	1699
	inch	70.87	70.87	19.69	66.77	66.89
HMET18186	mm	1800	1800	600	1696	1699
	inch	70.87	70.87	23.62	66.77	66.89
HMET18188	mm	1800	1800	800	1696	1699
	inch	70.87	70.87	31.50	66.77	66.89
HMET20105	mm	2000	1000	500	1896	899
	inch	78.74	39.37	19.69	74.65	35.40
HMET20106	mm	2000	1000	600	1896	899
	inch	78.74	39.37	23.62	74.65	35.40
HMET20124	mm	2000	1200	400	1896	1099
	inch	78.74	47.25	15.75	74.65	43.27
HMET20125	mm	2000	1200	500	1896	1099
	inch	78.74	47.25	19.69	74.65	43.27
HMET20126	mm	2000	1200	600	1896	1099
	inch	78.74	47.25	23.62	74.65	43.27
HMET20128	mm	2000	1200	800	1896	1099
	inch	78.74	47.25	31.50	74.65	43.27
HMET20165	mm	2000	1600	500	1896	1499
	inch	78.74	62.99	19.69	74.65	59.02
HMET20166	mm	2000	1600	600	1896	1499
	inch	78.74	62.99	23.62	74.65	59.02
HMET20168	mm	2000	1600	800	1896	1499
	inch	78.74	62.99	31.50	74.65	59.02
HMET20185	mm	2000	1800	500	1896	1699
	inch	78.74	70.87	19.69	74.65	66.89
HMET20186	mm	2000	1800	600	1896	1699
	inch	78.74	70.87	23.62	74.65	66.89
HMET20188	mm	2000	1800	800	1896	1699
	inch	78.74	70.87	31.50	74.65	66.89
HMET22106	mm	2200	1000	500	2096	899
	inch	86.62	39.37	19.69	82.52	35.40
HMET22125	mm	2200	1200	500	2096	1099
	inch	86.62	47.25	19.69	82.52	43.27
HMET22126	mm	2200	1200	600	2096	1099
	inch	86.62	47.25	23.62	82.52	43.27

Technical references and CAD downloads available at [www.hammondmfg.com](http://www.hammondmfg.com)

All dimensions in inches unless specified otherwise

**Quality Products. Service Excellence.**

## HFMD/HFMDT Series



HFMD - 1DR



HFMDT - 2DR

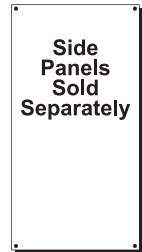

### Application

- The HFMD 1 door and HFMDT 2 door product lines provides users with a rugged housing for flange mount disconnect and circuit breaker requirements.
- Modular design permits joining of units together for large scale and mixed use applications.
- Frame's 25mm hole pattern provides extensive component and accessory mounting flexibility.
- A broad range of industry standard sizes are offered.
- HME/HMET Series enclosures can be used as slave units to HFMD/HFMDT Disconnect Series.
- The flange mount disconnect units accommodate today's most popular disconnect hardware.
- **ABB Controls:** Disconnect Switches up to (and including) 200 amp, also operators for ABB circuit breakers up to 800 amp.
- **Allen Bradley:** 1494V variable depth flange mounted disconnect up to and including 200 amp and operators for C-H Westinghouse circuit breakers up to 400 amp.
- **C-H Westinghouse:** C361 flange mounted disconnect switches up to and including 200 amp and C371 circuit breakers up to 600 amp, also Flex Shaft handle mechanisms for circuit breakers.
- **General Electric:** Type STDA flange mounted variable depth flange operators for disconnect switches up to and including 200 amp and circuit breakers up to 600 amp or Spectra Flex™ cable operators for circuit breakers.
- **ITE Siemens Max-Flex:** flange mounted variable depth cable operators for disconnect switches up to 200 amp and circuit breakers up to 600 amp.
- **Square D:** class 9422 variable depth flange mounted operating mechanisms for disconnect switches up to and including 200 amp or cable mechanism for 30, 60 or 100 amp, also circuit breakers with variable depth operators or cable mechanism up to 400 amp.

### Standards

- UL 508 Type 12
- CSA Type 12
- **Complies with**
  - NEMA Type 12
  - IEC 60529 IP54
- Appropriate components are required to maintain these standards.

### Standard Configuration

- Frame
- Removable solid top panel
- Lifting eyebolts (4)
- Removable bottom panel w/gland plates
- Solid front door(s) with door frame(s).
- Removable rear cover panel(s) – two door version with removable center post
- Inner mounting panel
- Disconnect to door handle activation hardware
- Hinged flange door

### Construction

- Formed 14 gauge steel.
- Fully welded frame with 25mm hole pattern for superior mounting flexibility.
- Seamless foam in place gasket.
- Reinforced eyebolts are provided for easy enclosure lifting.
- Frames can be joined together with an optional joining kit.
- Doors can be easily interchanged, removed and/or reversed.
- Door opening 135°.
- Optional formed 14 gauge steel side panels are sold separately (in pairs).
- Bonding and grounding studs are provided for all doors and panels.

### Finish

- Phosphatized and finished in RAL 7035 light gray powder coating.
- Inner panel is unpainted galvanized 12 gauge steel.

### Accessories

- 19" mounting rails
- Cooling - ACs
- Cooling - fans
- Door shelf
- Frame joining kit
- Grid mounting system
- Handles and inserts
- Interlock system
- Leveling feet
- Light kit and accessories
- Literature pocket
- Panel - Bridge
- Panel - Barrier
- Swing Panel
- Swing Frame
- Plinth
- Side panels
- Tamper resistant screws
- Top mount cable module



# HFMD/HFMDT Series

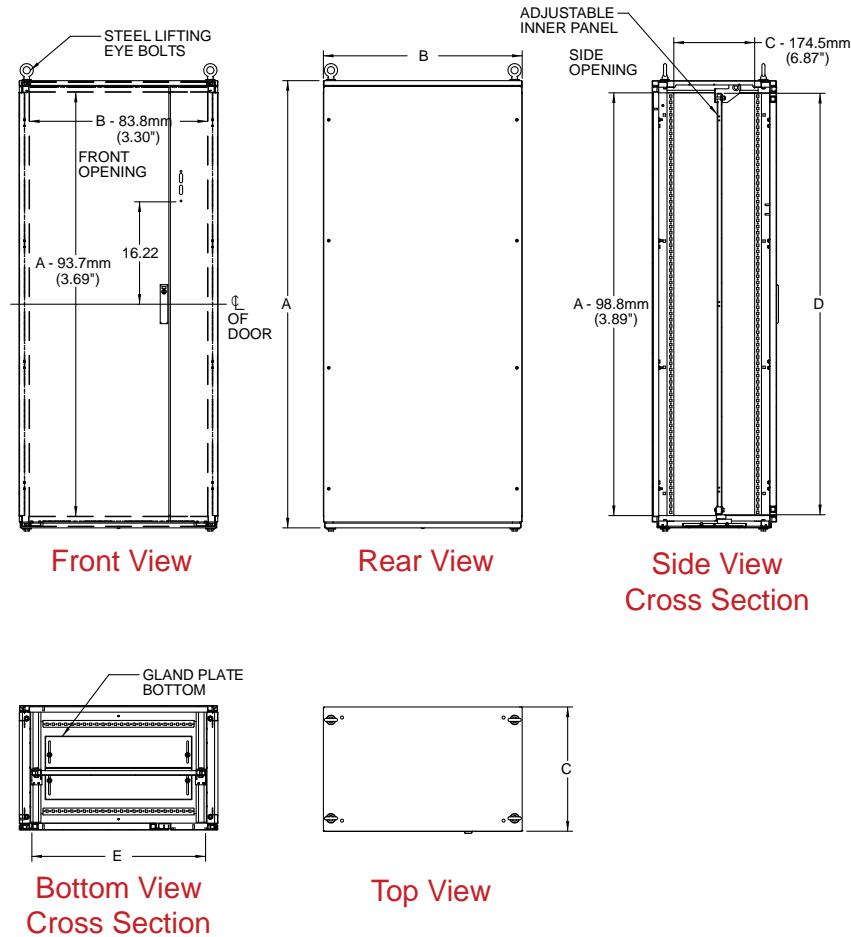

## Single Door

Part Number		Overall Dimensions			Panel Dimensions	
		A	B	C	D	E
HFMD1485	mm	1400	800	500	1296	699
	inch	55.12	31.5	19.69	51.03	27.52
HFMD14105	mm	1400	1000	500	1296	899
	inch	55.12	39.37	19.69	51.03	35.4
HFMD1685	mm	1600	800	500	1496	699
	inch	62.99	31.5	19.69	58.9	27.52
HFMD1686	mm	1600	800	600	1496	699
	inch	62.99	31.5	23.62	58.9	27.52
HFMD1884	mm	1800	800	400	1696	699
	inch	70.87	31.5	15.75	66.77	27.52
HFMD1885	mm	1800	800	500	1696	699
	inch	70.87	31.5	19.69	66.77	27.52
HFMD18105	mm	1800	1000	500	1696	899
	inch	70.87	39.37	19.69	66.77	35.4
HFMD2085	mm	2000	800	500	1896	699
	inch	78.74	31.5	19.69	74.65	27.52
HFMD2086	mm	2000	800	600	1896	699
	inch	78.74	31.5	23.62	74.65	27.52
HFMD2088	mm	2000	800	800	1896	699
	inch	78.74	31.5	31.5	74.65	27.52
HFMD20105	mm	2000	1000	500	1896	899
	inch	78.74	39.37	19.69	74.65	35.4
HFMD20106	mm	2000	1000	600	1896	899
	inch	78.74	39.37	23.62	74.65	35.4
HFMD2286	mm	2200	800	600	2096	699
	inch	86.62	31.5	23.62	82.52	27.52

## Double Door

Part Number		Overall Dimensions			Panel Dimensions	
		A	B	C	D	E
HFMDT18164	mm	1800	1600	400	1696	1499
	inch	70.87	62.99	15.75	66.77	59.02
HFMDT18165	mm	1800	1600	500	1696	1499
	inch	70.87	62.99	19.69	66.77	59.02
HFMDT18184	mm	1800	1800	400	1696	1699
	inch	70.87	70.87	15.75	66.77	66.89
HFMDT18185	mm	1800	1800	500	1696	1699
	inch	70.87	70.87	19.69	66.77	66.89
HFMDT18186	mm	1800	1800	600	1696	1699
	inch	70.87	70.87	23.62	66.77	66.89
HFMDT20165	mm	2000	1600	500	1896	1499
	inch	78.74	62.99	19.69	74.65	59.02
HFMDT20166	mm	2000	1600	600	1996	1499
	inch	78.74	62.99	23.62	78.58	59.02
HFMDT20168	mm	2000	1600	800	1896	1499
	inch	78.74	62.99	31.50	74.65	59.02
HFMDT20185	mm	2000	1800	500	1896	1699
	inch	78.74	70.87	19.69	74.65	66.89
HFMDT22105	mm	2200	1000	500	2096	899
	inch	86.61	39.37	19.69	82.52	35.39

## External Accessories



Side Panels sold separately

### Plinth

- Plinths install under enclosure for additional cable entry space and/or access
- Adds 4" (100mm) or 8" (200mm) to overall enclosure height.
- HPLW contains 4 corner supports along with corresponding front and rear panels.
- HPLD plinth side panels ordered separately to close ends.
- All panels are easily removable for quick access.
- Compatible with leveling feet.
- Comes complete with all mounting hardware.
- Finished in black.



#### Plinth Corners and Front/Back Panels

Part Number	Height (mm)	Use w/ HME Width (mm)
HPLW14	100	400
HPLW16	100	600
HPLW18	100	800
HPLW110	100	1000
HPLW112	100	1200
HPLW116	100	1600
HPLW118	100	1800
HPLW24	200	400
HPLW26	200	600
HPLW28	200	800
HPLW210	200	1000
HPLW212	200	1200
HPLW216	200	1600
HPLW218	200	1800

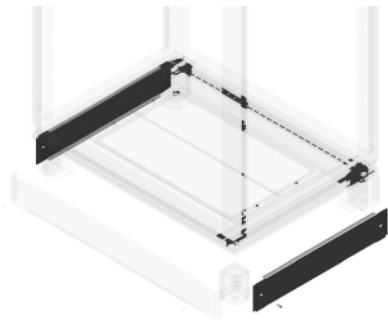

#### Plinth Side Panels (pair)

Part Number	Height (mm)	Use w/ HME Depth (mm)
HPLD14	100	400
HPLD15	100	500
HPLD16	100	600
HPLD18	100	800
HPLD24	200	400
HPLD25	200	500
HPLD26	200	600
HPLD28	200	800

#### Side Panels

Technical references and CAD downloads available at [www.hammondmfg.com](http://www.hammondmfg.com)

All dimensions in inches unless specified otherwise

**Quality Products. Service Excellence.**

## External Accessories

### Side Panels



- Maintains UL/CSA Type 12 approvals.
- Screws fasten into frame. Optional tamper resistant screws available
- Bond studs provided for grounding.
- Finished in RAL 7035 light gray.
- Sold in quantities of two.

Part Number	For Use with HME	
	Height (mm)	Depth (mm)
HSP145	1400	500
HSP146	1400	600
HSP148	1400	800
HSP165	1600	500
HSP166	1600	600
HSP168	1600	800
HSP184	1800	400
HSP185	1800	500
HSP186	1800	600
HSP188	1800	800
HSP204	2000	400
HSP205	2000	500
HSP206	2000	600
HSP208	2000	800
HSP225	2200	500
HSP226	2200	600
HSP228	2200	800



### Tamper Resistant Screws

- Replacement screws for side and rear panels.
- Provide added safety and security.
- Package consists of 8 security hex screws and 1 security hex key.
- Please see the chart below to determine how many kits to order.

Part No. **ISPTPKIT**

Component	# Screws Req'd	# Kits to Order
Side Panels (Pair)	16	2
Rear Panel (600, 700, 800, 1000 mm)	8	1
Rear Panel (1200, 1600 mm)	16	2



### Frame Joining Kit

- Heavy duty bolting kit connects side by side units at 8 points.
- Maintains UL/CSA Type 12 approvals.

Part Number	Description
HMEJK	Heavy duty frame bolting kit

# External Accessories

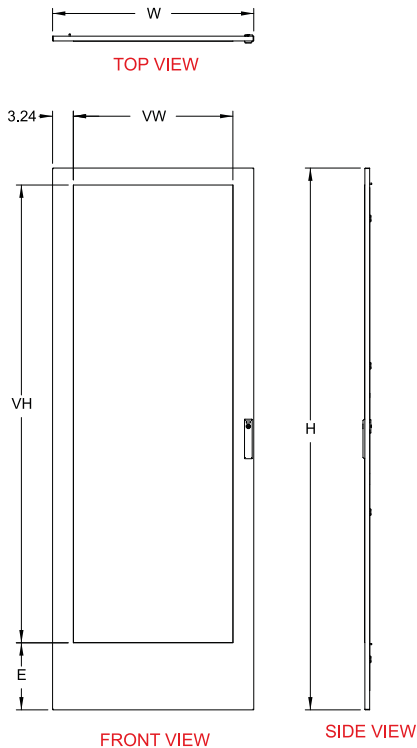

## Window Door

- For use with HME Series only
- Provides maximum viewing area of enclosure equipment
- Maintains NEMA/UL/CSA type 12 rating
- UL - 94-VO clear polycarbonate window
- Removable and reversible for left or right hand opening
- Complete with double bit insert latching mechanism
- **Note: check interface with HFMD and HFMDT**

Part No.	Viewing Area			For use with Cabinet		
	Height	Width	E	Height	Width	
<b>HMEDW146</b>	mm	1219	434	67	1400	600
	inch	47.98	17.10	2.64	55.12	23.62
<b>HMEDW148</b>	mm	1219	635	67	1400	800
	inch	47.98	24.98	2.64	55.12	31.5
<b>HMEDW166</b>	mm	1419	434	67	1600	600
	inch	55.85	17.10	2.64	62.99	23.62
<b>HMEDW168</b>	mm	1419	635	67	1600	800
	inch	55.85	24.98	2.64	62.99	31.5
<b>HMEDW186</b>	mm	1617	434	67	1800	600
	inch	63.67	17.10	2.64	70.87	23.62
<b>HMEDW188</b>	mm	1617	635	67	1800	800
	inch	63.67	24.98	2.64	70.87	31.5
<b>HMEDW206</b>	mm	1819	434	67	2000	600
	inch	71.6	17.10	2.64	78.74	23.62
<b>HMEDW208</b>	mm	1819	635	67	2000	800
	inch	71.6	24.98	2.64	78.74	31.5
<b>HMEDW226</b>	mm	1819	434	266	2200	600
	inch	71.06	17.10	10.49	86.62	23.62
<b>HMEDW228</b>	mm	1819	635	266	2200	800
	inch	71.06	24.98	10.49	86.62	31.5

## External Accessories



**Top Cabling Module**

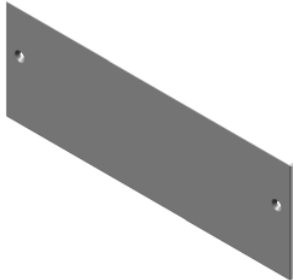

**Side Panels**



### Top Mount Cable Module and Side Panels

- Provides a space for cable organization along top of HME cabinet(s).
- Mounts directly to top of HME cabinet (with top panel removed) with matching WxD dimensions.
- Top Module consists of frame (similar to HME overall frame) with removable front and rear panels.
- Side panels (pair) sold separately. (Note: Standard top panel from HME cabinet fits on matching WxD version of Top Module).
- Finished in RAL7035 light gray.

Part Number	Description	H	W	D
<b>HTCM46</b>	Top Cabling Module	200	400	600
<b>HTCM66</b>	Top Cabling Module	200	600	600
<b>HTCM86</b>	Top Cabling Module	200	800	600
<b>HTCM106</b>	Top Cabling Module	200	1000	600
<b>HTCM126</b>	Top Cabling Module	200	1200	600
<b>HTCM346</b>	Top Cable Module	300	400	600
<b>HTCM366</b>	Top Cable Module	300	600	600
<b>HTCM386</b>	Top Cable Module	300	800	600
<b>HTCM3106</b>	Top Cable Module	300	1000	600
<b>HTCM3126</b>	Top Cable Module	300	1200	600
<b>HTCMS6</b>	Side Panels for 200mm Top Cabling Module	200	n/a	600
<b>HTCMS36</b>	Side Panels for 300 mm top Cable Module	300	n/a	600



### Leveling Feet

- Set of 4 leveling feet.
- 4 leveling feet will support a maximum of 2600 lbs static load
- 1.57" dia base
- Leveling foot adds 1.1" to overall height of cabinet when used with optional plinth. Adds 1.5" when used on cabinet frame base.

Part Number	Description
<b>HLF4</b>	Set of 4 feet



## Internal Accessories

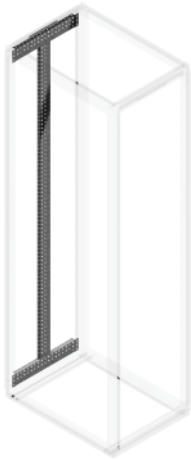

### Grid System

- Constructed of 14 gauge steel, galvanized.
- There are 4 styles: (1) 25mm wide Depth Grid Strap, (2) 75mm wide Depth Grid Strap, (3) 75mm wide Vertical Grid Strap and (4) 25mm wide Door Support Rail
- Grid Straps feature pattern of alternating square holes (for cage nut) and round holes (for M5 or #12 screw) at standard 25mm centers. Door Support Rails have round holes only.
- Depth Grid Straps and Door Support Rails have mounting flanges at either end.
- Vertical Grid Straps mount flush (butt end bracket included) to other straps for a smooth continuous mounting surface. (To achieve full height vertical strap, 2 x 75mm Depth Grid Straps required for top and bottom).
- Sold in pairs.



25mm



75mm

### Depth Grid Straps

Part Number	Description	Length (mm)	Fits Full Depth HME (mm)
HGD14	25mm wide with mounting flange	222	400
HGD15	25mm wide with mounting flange	323	500
HGD16	25mm wide with mounting flange	423	600
HGD18	25mm wide with mounting flange	623	800
HGD34	75mm wide with mounting flange	223	400
HGD35	75mm wide with mounting flange	323	500
HGD36	75mm wide with mounting flange	423	600
HGD38	75mm wide with mounting flange	623	800

# Internal Accessories



## Vertical Grid Straps

Part Number	Description	Length (mm)	Fits Full Height HME (mm)
HGV35	75mm wide with flush mount bracket	350	n/a
HGV55	75mm wide with flush mount bracket	550	n/a
HGV75	75mm wide with flush mount bracket	750	n/a
HGV95	75mm wide with flush mount bracket	950	n/a
HGV115	75mm wide with flush mount bracket	1150	1400*
HGV135	75mm wide with flush mount bracket	1350	1600*
HGV155	75mm wide with flush mount bracket	1550	1800*
HGV175	75mm wide with flush mount bracket	1750	2000*
HGV195	75mm wide with flush mount bracket	1950	2200*

\* - Requires 75mm wide Depth Grid Straps mounted in cabinet above and below.



## Door Support Rails

Part Number	Description	Length (mm)	Fits HME Door Width (mm)
HGDSR4	25mm wide with mounting flange	248	400
HGDSR5	25mm wide with mounting flange	348	500
HGDSR6	25mm wide with mounting flange	448	600
HGDSR8	25mm wide with mounting flange	648	800
HGDSR9	25mm wide with mounting flange	748	900*
HGDSR10	25mm wide with mounting flange	848	1000

\* - 900mm width refers to doors on 1800mm wide cabinet



## Grid Strap Spacer

- Constructed of 14 gauge steel galvanized
- Designed as a spacer for 75mm grid straps when mounted front to back on bottom flanges
- Can be used for terminal straps and grounding bars
- Sold in pairs

Part Number	Description
HGS3	Grid Spacer 75mm x 17.5mm

# Internal Accessories

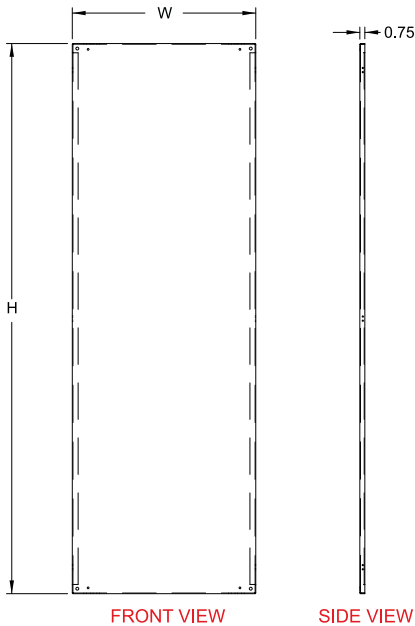

## Additional Inner Panels

- Formed 12 gauge galvanized steel unpainted
- Included with standard configuration
- Sold separately as secondary or replacement panel
- Can be used as swing panel (where indicated \* - sold separately)
- Inner panel attachment hardware sold separately as required

Part No.		Overall		For use with Cabinet	
		Height	Width	Height	Depth
HMEP146 *	mm	1296	499	1400	600
	inch	51.02	19.65	55.12	23.62
HMEP148 *	mm	1296	699	1400	800
	inch	51.02	27.52	55.12	31.50
HMEP1410	mm	1296	899	1400	1000
	inch	51.02	35.39	55.12	39.37
HMEP1412	mm	1296	1099	1400	1200
	inch	51.02	43.27	55.12	47.25
HMEP166 *	mm	1296	499	1600	600
	inch	58.90	19.65	62.99	23.62
HMEP168 *	mm	1496	699	1600	800
	inch	58.90	27.52	62.99	31.50
HMEP1612	mm	1496	1099	1600	1200
	inch	58.90	43.27	62.99	47.25
HMEP186 *	mm	1496	499	1800	600
	inch	66.77	19.65	70.87	23.62
HMEP188 *	mm	1696	699	1800	800
	inch	66.77	27.52	70.87	31.50
HMEP1810	mm	1696	899	1800	1000
	inch	66.77	35.39	70.87	39.37
HMEP1812	mm	1696	1099	1800	1200
	inch	66.77	43.27	70.87	47.25
HMEP1816	mm	1696	1499	1800	1600
	inch	66.77	59.02	70.87	62.99
HMEP1818	mm	1660	1699	1800	1800
	inch	66.77	66.89	70.87	70.87
HMEP204	mm	1660	299	2000	400
	inch	74.65	11.77	78.74	15.75
HMEP206 *	mm	1896	499	2000	600
	inch	74.65	19.65	78.74	23.62
HMEP208 *	mm	1896	699	2000	800
	inch	74.65	27.52	78.74	31.50
HMEP2010	mm	1896	899	2000	1000
	inch	74.65	35.39	78.74	39.37
HMEP2012	mm	1896	1099	2000	1200
	inch	74.65	43.27	78.74	47.25
HMEP2016	mm	1896	1499	2000	1600
	inch	74.65	59.02	78.74	62.99
HMEP2018	mm	1896	1699	2000	1800
	inch	74.65	66.89	78.74	70.87
HMEP224	mm	1896	299	2200	400
	inch	74.65	11.77	86.62	15.75
HMEP226 *	mm	1896	499	2200	600
	inch	82.52	19.65	86.62	23.62
HMEP228 *	mm	2096	6990	2200	800
	inch	82.52	27.52	86.62	31.50
HMEP2210	mm	2096	899	2200	1000
	inch	82.52	35.39	86.62	39.37
HMEP2212	mm	2096	1099	2200	1200
	inch	82.52	43.27	86.62	47.25



## Inner panel hardware

- Required to install above inner panels to HME frame

Part Number	Description
HMEIPMTG	Inner panel Mounting hardware

# Internal Accessories

## Side Mounting Inner panels

- Sold individually
- Formed 12 gauge galvanized steel unpainted
- Mounts directly to frame
- Can be used in combination with depth grid straps (top and bottom)
- Allows installation of 19" mounting rails including center support
- Reduced height may allow cable pass through on ganged cabinets

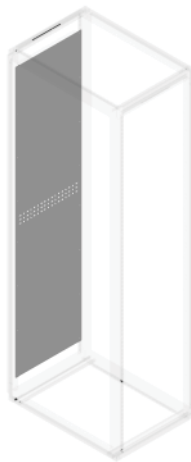
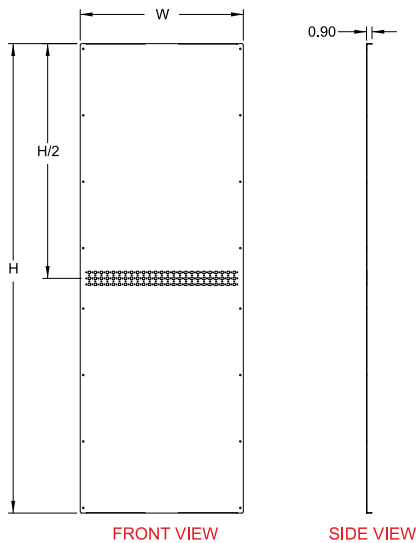

Part No.		Overall		For use with Cabinet	
		Height	Width	Height	Depth
<b>HSIP145</b>	mm	1143	375	1400	500
	inch	45.00	14.76	55.12	19.65
<b>HSIP146</b>	mm	1143	475	1400	600
	inch	45.00	18.70	55.12	23.62
<b>HSIP148</b>	mm	1143	675	1400	800
	inch	45.00	26.57	55.12	31.5
<b>HSIP165</b>	mm	1343	375	1600	500
	inch	52.87	14.76	62.99	19.65
<b>HSIP166</b>	mm	1343	475	1600	600
	inch	52.87	18.7	62.99	23.62
<b>HSIP168</b>	mm	1343	675	1600	800
	inch	52.87	26.57	62.99	31.5
<b>HSIP184</b>	mm	1543	275	1800	400
	inch	60.74	10.82	70.87	15.75
<b>HSIP185</b>	mm	1543	375	1800	500
	inch	60.74	14.76	70.87	19.65
<b>HSIP186</b>	mm	1543	475	1800	600
	inch	60.74	18.70	70.87	23.62
<b>HSIP188</b>	mm	1573	675	1800	800
	inch	60.74	26.57	70.87	31.5
<b>HSIP204</b>	mm	1743	275	2000	400
	inch	68.62	10.82	78.74	15.75
<b>HSIP205</b>	mm	1743	375	2000	500
	inch	68.72	14.76	78.74	19.69
<b>HSIP206</b>	mm	1743	475	2000	600
	inch	68.72	18.70	78.74	23.62
<b>HSIP208</b>	mm	1743	675	2000	800
	inch	68.72	26.57	78.74	31.5
<b>HSIP225</b>	mm	1943	375	2200	500
	inch	76.49	14.76	86.62	19.69
<b>HSIP226</b>	mm	1943	475	2200	600
	inch	76.49	18.70	86.62	23.62
<b>HSIP228</b>	mm	1943	675	2200	800
	inch	76.49	16.57	86.62	31.5

# Internal Accessories

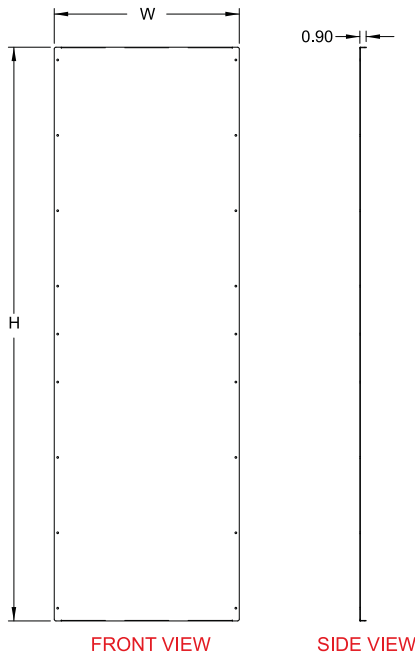

## Side Mounting Barrier Panels



- Sold individually
- Formed 12 gauge galvanized steel unpainted
- Mounts directly to frame
- Full height and depth panel creating a full barrier between cells
- No provision for depth grid straps or 19" mounting rails
- Can be used as a mounting surface

Part No.		Overall		For use with Cabinet	
		Height	Width	Height	Depth
<b>HSBP145</b>	inch	1293	375	1400	500
	mm	50.90	14.76	55.12	19.65
<b>HSBP146</b>	inch	1293	475	1400	600
	mm	50.90	18.70	55.12	23.62
<b>HSBP148</b>	inch	1293	675	1400	800
	mm	50.90	26.57	55.12	31.5
<b>HSBP165</b>	inch	1493	375	1600	500
	mm	58.78	14.76	62.99	19.65
<b>HSBP166</b>	inch	1493	475	1600	600
	mm	58.78	18.70	62.99	23.62
<b>HSBP168</b>	inch	1493	675	1600	800
	mm	58.78	26.57	62.99	31.5
<b>HSBP184</b>	inch	1693	275	1800	400
	mm	66.65	10.82	70.87	15.75
<b>HSBP185</b>	inch	1693	375	1800	500
	mm	66.65	14.76	70.87	19.65
<b>HSBP186</b>	inch	1693	475	1800	600
	mm	66.65	18.70	70.87	23.62
<b>HSBP188</b>	inch	1693	675	1800	800
	mm	66.65	26.57	70.87	31.5
<b>HSBP204</b>	inch	1893	275	2000	400
	mm	74.53	10.82	78.74	15.75
<b>HSBP205</b>	inch	1893	375	2000	500
	mm	74.53	14.76	78.74	19.69
<b>HSBP206</b>	inch	1893	475	2000	600
	mm	74.53	18.70	78.74	23.62
<b>HSBP208</b>	inch	1893	675	2000	800
	mm	74.53	26.57	78.74	31.5
<b>HSBP225</b>	inch	2093	375	2200	500
	mm	82.40	14.76	86.62	19.69
<b>HSBP226</b>	inch	2093	475	2200	600
	mm	82.40	18.70	86.62	23.62
<b>HSBP228</b>	inch	2093	675	2200	800
	mm	82.40	26.57	86.62	31.5

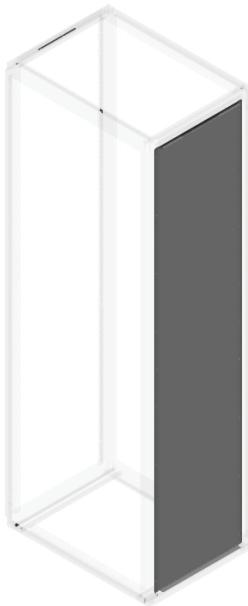



## Internal Accessories

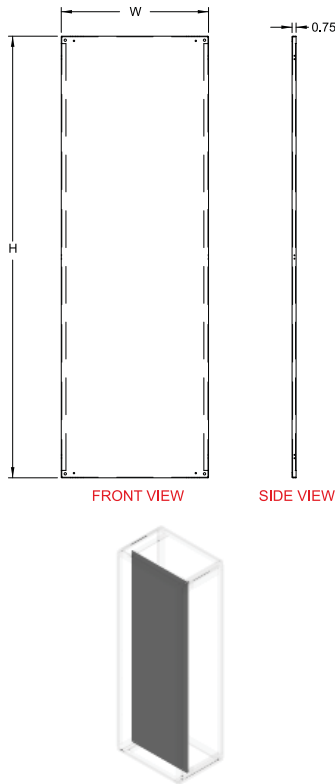

### Swing Panel

- Formed 12 gauge galvanized steel unpainted
- Requires Swing Kit sold separately

Part No.		Overall		For use with Cabinet	
		Height	Width	Height	Width
<b>HMEP146</b>	mm	1296	499	1400	600
	inch	51.03	23.62	55.12	23.62
<b>HMEP148</b>	mm	1296	699	1400	800
	inch	51.03	27.52	55.12	31.5
<b>HMEP166</b>	mm	1496	499	1600	600
	inch	58.9	23.62	62.99	23.62
<b>HMEP168</b>	mm	1496	699	1600	800
	inch	58.9	27.52	62.99	31.5
<b>HMEP186</b>	mm	1696	499	1800	600
	inch	66.77	23.62	70.87	23.62
<b>HMEP188</b>	mm	1696	699	1800	800
	inch	66.77	27.52	70.87	31.5
<b>HMEP206</b>	mm	1896	499	2000	600
	inch	74.65	23.62	78.74	23.62
<b>HMEP208</b>	mm	1896	699	2000	800
	inch	74.65	27.52	78.74	31.5
<b>HMEP226</b>	mm	2096	499	2200	600
	inch	82.52	23.62	86.62	23.62
<b>HMEP228</b>	mm	2096	699	2200	800
	inch	82.52	27.52	86.62	31.5



Shown with optional door support rails

### Shelf

- Mounts to internal door channel using 1 or 2 door support rails (sold separately) or directly to a door/side panel using supplied hardware.
- Can be easily positioned at various heights.
- Opens to 90° or 75° angle and quickly folds down for compact storage.
- Finished in RAL 7035 light gray.

Part Number	Width	Depth
<b>DMS1615</b>	16	15

### Bridge Panel

- Mounts between inner panels of joined enclosures.
- Unpainted galvanized 12 gauge steel.
- 3.75" wide.



Part Number	For Use with Cabinet Height
<b>HMEPB14</b>	1400
<b>HMEPB16</b>	1600
<b>HMEPB18</b>	1800
<b>HMEPB20</b>	2000
<b>HMEPB22</b>	2200

## Internal Accessories

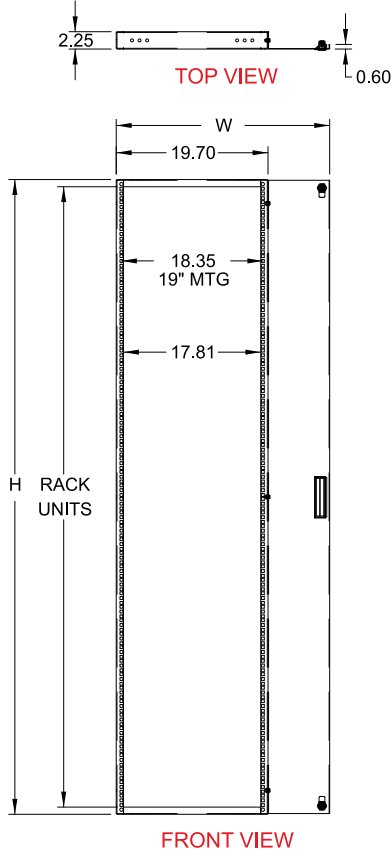

### Swing Frame for 19" Mounting

- Frame provides 19" rack mounting centers
- Rails punched for square holed cage nuts
- Finished in RAL7035
- Requires Swing Kit sold separately

Part No.	Overall		Rack Units	For use with Cabinet	
	Height	Width		Height	Width
<b>HMESWF166</b>	mm	1494	32	1600	600
	inch	58.80			
<b>HMESWF168</b>	mm	1494	32	1600	800
	inch	58.80			
<b>HMESWF186</b>	mm	1694	37	1800	600
	inch	66.68			
<b>HMESWF188</b>	mm	1694	37	1800	800
	inch	66.68			
<b>HMESWF206</b>	mm	1894	41	2000	600
	inch	74.55			
<b>HMESWF208</b>	mm	1894	41	2000	800
	inch	74.55			
<b>HMESWF226</b>	mm	2094	45	2200	600
	inch	82.43			
<b>HMESWF228</b>	mm	2094	45	2200	800
	inch	82.43			



### Swing Kits

- Used in conjunction with HMEP Swing Panels or HMESWF Swing Frames
- Provides adjustable location for panels and frame front to rear
- Comes complete with all mounting hardware
- Finished in RAL7035



Part Number	Description
<b>HMESWK4</b>	Fits 400mm depth frame
<b>HMESWK5</b>	Fits 500mm depth frame
<b>HMESWK6</b>	Fits 600mm depth frame
<b>HMESWK8</b>	Fits 800mm depth frame

## Internal Accessories

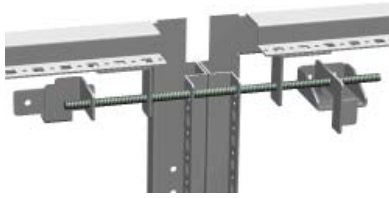

**Master Interlock  
(Rod included)**

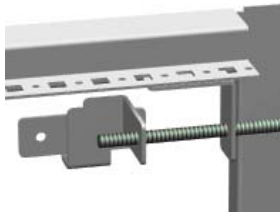

**Slave Interlock  
(Rod sold separately)**

### Interlock Kit for HME, HFMD, HMET & HFMTD

- Master Interlock Kit- required for master door in system
- Slave Interlock Kit- required for each slave door to be interlocked with master door
- Rod connector kit- required for connecting to slave kit
- Clear zinc plated
- All kits maintain UL/CSA Type 12 approvals

Part Number	Description
<b>HMIK</b>	Master Interlock Kit
<b>HSIK</b>	Slave Interlock Kit
<b>HSCRD</b>	Rod Connector kit 600-1200 wide

Ordering Guide Common assemblies	Required
Single Door (Master Right or left) to Single door Cabinet	Master Interlock Kit
Single Door (Master right) to Double door Cabinet	Master Interlock Kit
Single Door (Master left) to Double door cabinet	Master Interlock Kit + Rod Connector Kit
Double Door (Master Right or Left) to Double door Cabinet	Master Interlock Kit + Rod Connector Kit
Any Additional cabinets to any of the above configurations	Slave + Rod Connector kit



**L Rail**



**Combination Rail**

### 19" Rails and Width Adapter Kits

- Provides 19" rack mounting centers in 600mm wide cabinets.
- Provides 19" rack mounting centers in 800mm wide cabinets when combined with Width Adapter Kits (Part # **HAK19800**).
- Can mount directly to frame in full front and full back positions or can have full front to back depth adjustment when used with Depth Grid Straps (sold separately).
- Rails are 12 gauge, include mounting hardware and are clear zinc plated (ZPL) finish.
- Square holed rails are made of 12 gauge steel with full EIA centers.
- Sold in pairs.

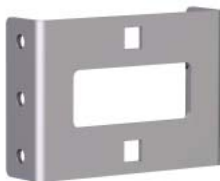

**HAK19800**

Part Number	Style	Mounting Space		Use with H (mm)
		U	Inches	
<b>HPR16SZPL</b>	Panel (L shape)	33	57.75	1600
<b>HPR18SZPL</b>	Panel (L shape)	38	66.50	1800
<b>HPR20SZPL</b>	Panel (L shape)	42	73.50	2000
<b>HPR22SZPL</b>	Panel (L shape)	47	82.25	2200
<b>HCR16SZPL</b>	Combination	33	57.75	1600
<b>HCR18SZPL</b>	Combination	38	66.50	1800
<b>HCR20SZPL</b>	Combination	42	73.50	2000
<b>HCR22SZPL</b>	Combination	47	82.25	2200

Part Number	Description
<b>HAK19800</b>	Adapts 800mm wide cabinets to 19" rack mounting (includes 4 brackets)

## Internal Accessories

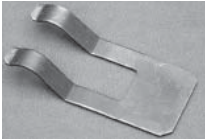

RCNIT - Cage nut  
insertion tool

### Grid Mounting Hardware

- A variety of hardware options are available for the Grid System.
- Square holes accommodate cage nuts listed.
- Round holes accommodate M5 and #12 thread forming screws listed.

#### Square Hole Hardware

Part Number	Description
RCNIT	Cage nut insertion tool
1421CNA25	25 of 10-32 cage nut
1421CNA100	100 of 10-32 cage nut
1421D	25 of Panhead #10-32 Slot/Phillips x 0.5"
1421CND25	25 of ¼-20 cage nut
1421CND100	100 of ¼-20 cage nut
1421SP142025	25 of Panhead ¼-20 Slot/Phillips x 0.5"
1421CNB25	25 of M6 cage nut
1421CNB100	100 of M6 cage nut
1421CNBF100	100 of M6 front load cage nut
1421HPM625	25 of Hex/Phillips M6 screws x 12mm

#### Round Hole Hardware

Part Number	Description
1421HPTM525	25 of Hex/Phillips Threadrolling M5 screws x 12mm
1421CT25	25 of Pan/Phillips Threadrolling #12-24 screws x 0.5"



### Ground Wire Kits

- Stranded #10 gauge copper wire with ring terminal .256 dia hole
- Includes mounting nuts both 1/4-20 and 10-32 ground studs
- Ground symbols (2 for each jumper)

Part Number	Description
GRDKIT01	Quantity 2
GRDKIT02	Quantity 6

### Ground Bar Kits

- Solid copper 1" x .125" with 10-32 drilled and tapped holes and 1- .312 main ground point
- Mounts directly to grid straps or frame mounting surface



Hardware  
Included

Part Number	Description
GRDBAR600	400mm length for 600 mm wide enclosures
GRDBAR800	600mm length for 800 mm wide enclosures

# System Accessories



## Inserts

- Standard door hardware is an escutcheon plate with double bit insert.
- A variety of other inserts (and matching keys) available as alternatives.

Part Number	Type	Description
HMESQI7	Insert	For escutcheon - 7mm square
HMESQI8	Insert	For escutcheon - 8mm square
HMETRI6	Insert	For escutcheon - 6.5mm triangle
HMETRI7	Insert	For escutcheon - 7mm triangle
HMETRI8	Insert	For escutcheon - 8mm triangle
HMEDBPI	Insert	For escutcheon - double bit w/3mm pin
HMESLCPI	Insert	For escutcheon - slot - coin proof
HMENLINS	Insert	For HMEHLKL non-locking insert
2SQK7	Key	For escutcheon - 7mm square
HMESQK8	Key	For escutcheon - 8mm square
HMETRK6	Key	For escutcheon - 6.5mm triangle
2TRK7	Key	For escutcheon - 7mm triangle
HMETRK8	Key	For escutcheon - 8mm triangle
HMEDBPK	Key	For escutcheon - double bit w/3mm pin
PMKEY	Key	For escutcheon - standard double bit



HMEHSKL



HMEHSKLPL



HMEHLKL/  
HMEHLNL

## Handles

- Standard escutcheon plate and insert can be replaced with several handle options.
- Die cast Swing Handles (black) open door with a rotating motion, are key-locking and available with padlocking feature.
- Heavy duty die cast Lift Handles (light gray) open door with an ergonomic lift up motion and are key-locking.

Part Number	Description
HMEHSKL	Diecast swing handle with key locking (black)
HMEHSKLPL	Diecast swing handle with key locking and padlockable (black)
HMEHLKL	Diecast lift handle with key locking (RAL7035 Gray)
HMEHLNL	Diecast lift handle non-locking (RAL7035 Gray)

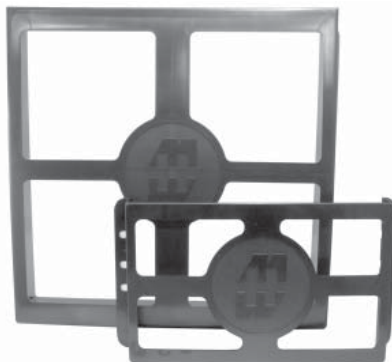

## Print Pocket

- For use as additional or replacement literature pockets.
- Kit includes pocket, high strength two-sided adhesive tape and surface preparation swab.
- Plastic pocket is black.
- Packaged individually.

Part No.	Height	Width	Depth
PKT66	6	6	0.75
PKT99	6	9	0.75
PKT1212	12	12	2.50



# Climate Control Overview

## Climate Control Selection Table

Choose from simple yet effective filterfan and exhaust grille combinations to closed loop Air Conditioners for your most demanding cooling applications.

Heating for condensation prevention and internal temperature controls in either Celsius or Fahrenheit.



### Type 12 Filter Fan

Performance Rating	Overall Dimensions			Part Number			Exhaust Grille Part Number	
	H	W	D	115 volt	230 volt	460 volt 3 phase		
17 CFM Type 12	inch	4.3	4.3	2.6	PF11000T12LG	PF11000T12LG230	N/A	PFA10000LG
	mm	109	109	66				
38 CFM Type 12	inch	4.9	4.9	2.9	PF22000T12LG	PF22000T12LG230	N/A	PFA20000LG
	mm	125	125	75				
65 CFM Type 12	inch	7.9	7.9	3.7	PF32000T12LG	PF32000T12LG230	N/A	PFA30000LG
	mm	202	202	93				
94 CFM Type 12	inch	9.9	9.9	4	PF42500T12LG	PF42500T12LG230	N/A	PFA40000LG
	mm	252	252	103				
169 CFM Type 12	inch	9.9	9.9	4.7	PF43000T12LG	PF43000T12LG230	N/A	PFA40000LG
	mm	252	252	119				
295 CFM Type 12	inch	12.6	12.6	6.2	PF65000T12LG	PF65000T12LG230	N/A	PFA60000LG
	mm	320	320	157				
462 CFM Type 12	inch	12.6	12.6	6.2	PF66000T12LG	PF66000T12BK230	PF66000T12LG460	PFA60000LG
	mm	320	320	157				
560 CFM Type 12	inch	12.6	12.6	6.2	PF67000T12LG	PF67000T12LG230	PF6700AT12LG460	PFA60000LG
	mm	320	320	157				

(CFM Rating of Fan&Filter combination)



### Type 12 Top Mount Filter Fan

Performance Rating	Overall Dimensions			Part Number			Exhaust Grille Part Number	
	H	W	D	115 volt	230 volt	460 volt 3 phase		
149 CFM Type 12	inch	16.9	16.9	2.9	PTF60500LG	PTF60500LG230	N/A	PFA60000LG
	mm	430	430	75				
227 CFM Type 12	inch	18.5	18.5	3.5	PTF60700LG	PTF60700LG230	PTF60700LG460	PFA60000LG
	mm	470	470	90				
304 CFM Type 12	inch	18.5	18.5	3.5	PTF61000LG	PTF61000LG230	N/A	PFA60000LG
	mm	470	470	90				
Top Mount Filter	inch	16.9	16.9	2.9				PTFA60000LG
	mm	430	430	75				



### Controls

Part Number	Overall Dimensions			Description	
	H	W	D		
SKT011409NC	inch	2.8	1.6	1.7	NC Thermostat Fahrenheit 15A AC 120V, 10A AC 250V
	mm	72	40	42	32° - 140° F
SKT011419NO	inch	2.8	1.6	1.7	NO Thermostat Fahrenheit 15A AC 120V, 10A AC 250V
	mm	72	40	42	32° - 140° F
SKT011409NC-C	inch	2.8	1.6	1.7	NC Thermostat Celsius 15A AC 120V, 10A AC 250V
	mm	72	40	42	0° - 60° F
SKT01119NO-C	inch	2.8	1.6	1.7	NO Thermostat Celsius 15A AC 120V, 10A AC 250V
	mm	72	40	42	0° - 60° F



### Heater Fan & Thermostat

Performance	Overall Dimensions			Part Number		
	H	W	D	115 v	230 v	
125 Watt	inch	5.5	4	5.3	FLHTF125A115	FLHTF125A230
	mm	135	102	135		
200 Watt	inch	5.5	4	5.5	FLHTF200A115	FLHTF200A230
	mm	135	102	135		
400 Watt	inch	7.5	4	5.3	FLHTF400A115	FLHTF400A230
	mm	190	102	135		
800 Watt	inch	7.5	4	5.3	FLHTF800A115	FLHTF800A230
	mm	190	102	135		

Technical references and CAD downloads available at [www.hammondmfg.com](http://www.hammondmfg.com)

All dimensions in inches unless specified otherwise

# Climate Control Overview

## Climate Control Selection Table



### Side Mount Type 12 Air Conditioners

Performance Rating		Overall Dimensions			Part Number		
		H	W	D	115 volt	230 volt	460 volt 3 phase
900-1,200 BTU	inch	13	14.8	7.5	DTS1200A115LG	DTS1200A230LG	N/A
	mm	330	375	190			
1,700-2,000 BTU	inch	17.5	12.4	10	DTS2000A115LG	DTS2000A230LG	N/A
	mm	444	314	254			
2,000 - 3,000 BTU	inch	20.2	10.9	10.8	DTS3041A115LG	DTS3041A230LG	N/A
	mm	518	276	275			
3,000 - 4000 BTU	inch	29.3	15.6	11.6	DTS3141A115LG	DTS3141A230LG	DTS3141A460LG
	mm	744	396	296			
5,000 - 7,000 BTU	inch	36	12	12	DTS3145A115LG	DTS3145A230LG	DTS3145A460LG
	mm	914	304	304			
7,000 - 8,500 BTU	inch	47.6	15.6	12.8	DTS3241A115LG	DTS3241A230LG	DTS3241A460LG
	mm	1209	396	325			
9000 - 12,000 BTU	inch	53	16	11.9	DTS3245A115LG	DTS3245A230LG	DTS3245A460LG
	mm	1346	406	302			
12,000 - 14,000 BTU	inch	59.1	15.9	18.4	N/A	DTS3341A230LG	DTS3341A460LG
	mm	1318	403	467			
16,000 - 18,000 BTU	inch	59.1	19	21	N/A	DTS3541A230LG	DTS3541A460LG
	mm	1318	483	533			
20,000 - 24,000 BTU	inch	65.6	19	24.5	N/A	DTS3641A230LG	DTS3641A460LG
	mm	1666	483	533			



### Top Mount Type 12 Air Conditioners

Performance Rating		Overall Dimensions			Part Number		
		H	W	D	115 volt	230 volt	460 volt 3 phase
1,200 - 2,000 BTU	inch	17	23.4	15.6	DTT6101A115LG	DTT6101A230LG	N/A
	mm	432	595	396			
2,500 - 4,000 BTU	inch	17	23.4	15.6	DTT6201A115LG	DTT6201A230LG	DTT6201A460LG
	mm	432	595	396			
4,000- 5,500 BTU	inch	17	23.4	19.5	DTT6301A115LG	DTT6301A230LG	DTT6301A460LG
	mm	432	595	495			
5,500 - 7,000 BTU	inch	17	23.4	19.5	DTT6401A115LG	DTT6401A230LG	DTT6401A460LG
	mm	432	595	495			
7,000 - 10,000 BTU	inch	19.1	31.3	22.6	N/A	N/A	DTT6601A460LG
	mm	485	795	575			
12,000 - 14,000 BTU	inch	19.1	31.3	22.6	N/A	N/A	DTT6801A460LG
	mm	485	795	575			

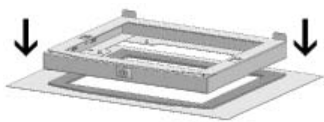

### Top Mount Frame Accessory

Part Number		Overall Dimensions			Use with
		H	W	D	
DTT61016202LG	inch	2.2	23.4	15.6	DTT6101-6201
	mm	56	595	396	
DTT63016401LG	inch	2.2	23.4	19.5	DTT6301-6401
	mm	56	595	495	
DTT66016801LG	inch	2.2	31.3	22.6	DTT6601-6801
	mm	56	795	575	

## Lighting and Accessories



### T8 Fluorescent Light Kits

- Available in 18", 24" and 48" lengths.
- Operating voltage 115 AC 60Hz
- Manual operated switch with 115 volt convenience outlet
- Metal housing finish in white, durable plastic lens with 6' power cord (without plug)
- Can mount to available light bracket (see below) or magnet strip
- Low profile 1.75" high x 4.5" deep
- Use standard 18", 24" or 48" T8 Fluorescent bulb (not included)

Part Number	Description
FLK18T8	18" Fluorescent Light Kit
FLK24T8	24" Fluorescent Light Kit
FLK48T8	48" Fluorescent Light Kit
FLK18MM	Magnet mount for 18" and 24" light
FLK48MM	Magnet mount for 48" light



### LED Light Kits

- Available in 9", 17.5", 26", 34.5" and 38.5" lengths
- Operating voltage 100/240V AC 50/60Hz Operating temperature -20 C to + 50 C
- Long lamp life 60,000 hours in warm white color temperature
- No remote power supplies as unit comes with its own integral LED drivers
- Hard wired via multiple knockouts in light weight extruded Aluminum frame finished white with manual operated switch
- Hinged glass diffuser allows easy access to replaceable LED module

Part Number	Description	Number LED Modules	Energy Use
FLK5LED	9" LED Light Kit	1	4.4 w
FLK7LED	17.5" LED Light Kit	2	7.2 w
FLK10LED	26" LED Light Kit	3	9.8 w
FLK15LED	34.5" LED Light Kit	4	15.0 w
FLK17LED	38.5" LED Light Kit	5	17.0 w



### Light Kit Brackets

- Designed for mounting to HME frame assembly
- Brackets accept either Fluorescent or LED light kits
- Clear coat plated finish

Part Number	Description
FLMTGBRK	Light kit mounting bracket 1.5" x 9" qty 2

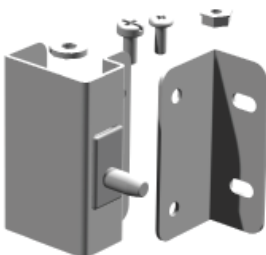

### Door switch

- Designed for mounting to HME frame assembly
- NO/NC switch rated 10A 115/230 volt

Part Number	Description
FDS1	Door Switch HME

## HME Modification Services

The standard offering of the HME Modular Enclosure System provides tremendous flexibility for equipment mounting and accessory enhancements. If, however, you are looking for a customized solution, Hammond can use the HME platform and create exactly what you need.

### Modification Options

- Special paint colors
- Holes and cutouts
- Unique factory configurations
- Custom sizes
- Mounting panel customization

### Custom Accessories

- Window Doors
- Split Doors
- Swing Panels
- Swing Frames
- Custom brackets
- And more



Your Colours



Your Holes & Cutouts

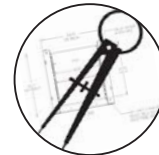

Your Dimensional Needs

**Contact your local Hammond sales representative today to discuss your modified product requirements.**

## Complementary Hammond Series



### IPC Series Type 12 PC Enclosures

The IPC product line provides users a workstation with a rugged housing for industrial control, operator interface and computer equipment in harsh industrial environments.

Increasingly, data must be accessed directly from the factory floor. The IPC enclosure provides a secure housing for standard PC components. A broad range of industry standard sizes are offered.



**S2000 Modular  
Consoles**



**Suspension  
Systems**



**Thousands of other enclosure solutions**

Visit [www.hammondmfg.com](http://www.hammondmfg.com)  
for technical specifications

**CANADA:**

Hammond Manufacturing Co. Ltd.  
394 Edinburgh Rd North  
Guelph , ON N1H 1E5  
Tel: (519) 822-2960  
Fax: (519) 822-0715

Les Fabrications Hammond Inc.  
4240 Rue Seré  
St. Laurent, Quebec H4T 1A6  
Tel: (514) 343-9010  
Fax: (514) 343-9941

**USA:**

Hammond Mfg. Co. Inc.  
475 Cayuga Rd.  
Cheektowaga, NY 14225  
Tel: (716) 630-7030  
Fax: (716) 630-7042

**Want more information on Hammond Products?**



**Industrial & Commercial Electrical Enclosures**

Industrial & Commercial Electrical Enclosures



**Electronic Racks & Cases**



**Power Bars & Surge Suppressors**



**Small Electronic Enclosures**



**Electronic Transformers**

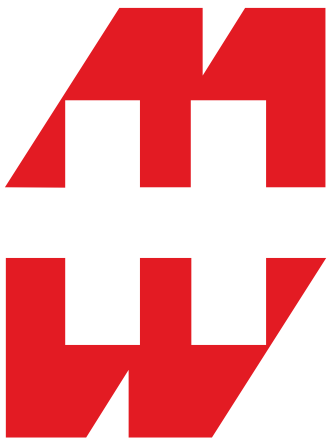

**Fax to:** For USA Requests:  
Hammond Manufacturing  
(716) 630-7042

**For Canadian & International Requests:**  
Hammond Manufacturing  
(519) 822-0715

**Website:** [www.hammondmfg.com](http://www.hammondmfg.com)

**e-mail:** [sales@hammfg.com](mailto:sales@hammfg.com)

Please send me these catalogs:		Price Lists	
Catalog Name	Qty	USA	CDN
Industrial & Commercial Electrical Enclosures			
Electronic Racks & Cases			
Small Electronic Enclosures			
Outlet Strips & Surge Suppressors			
Electronic Transformers			
Other — Please note if there are other products you are interested in:			

Name: \_\_\_\_\_

Company: \_\_\_\_\_

Street Address: \_\_\_\_\_

City, State/Province: \_\_\_\_\_

Zip/Postal Code: \_\_\_\_\_

E-mail address: \_\_\_\_\_

Telephone Number: ( ) \_\_\_\_\_

Fax Number: ( ) \_\_\_\_\_

ATTACH BUSINESS CARD HERE

**UNITED KINGDOM:**

Hammond Electronics Limited  
1 Onslow Close  
Kingsland Business Park  
Basingstoke, Hampshire,  
RG24 8QL  
Tel: +44 1256 812812  
Fax: +44 1256 332249

**AUSTRALIA:**

Hammond Electronics Pty. LTd.  
11-13 Port Road  
Queenstown, SA 5014  
Tel: +61 8 8240 2244  
Fax: +61 8 8240 2255